

## SEC-H-R2R/U REMOTE 2 READER MODULE

### INSTALLATION INSTRUCTIONS

This document covers the mounting and wiring of a Remote 2 Reader Module (SEC-H-R2R/U), for expanding a WEBS-AX® Security Controller (SEC-H-602, or SEC-H-616). It assumes that you are an engineer, technician, or service person who is performing access system design or installation. Please read through this entire document before beginning the installation procedures.

These are the main topics included in this document:

- Product Description, page 1
- Preparation, page 2
- Precautions, page 3
- Installation and Start-up Outline, page 4
- Physical Mounting, page 4
- SEC-H-R2R/U Board Layout and Terminal Locations, page 6
- Wiring Overview, page 7
- Security I/O Wiring, page 9
- RS-485 Communications, page 16
- Power and Backup Battery, page 17
- Power Up and Initial Checkout, page 20
- UL Requirements, page 21
- New Replacement Units, page 21
- Replacing an SEC-H-R2R/U Module, page 22
- Certifications, page 24

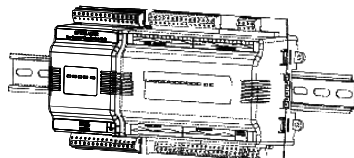

This document does not discuss mounting and wiring of other components, or software configuration. For more information on these topics, refer to documents listed in Related Documentation, page 2.

## PRODUCT DESCRIPTION

The WEBS-AX Remote 2 Reader Module expands a WEBS-AX Security Controller (SEC-H-602, or SEC-H-616 shortened to security controller) to support two (2) additional access doors. Provided are two card reader inputs (for 12V Wiegand-type readers), two Form-C relay outputs, and four supervised digital inputs. Also included are two digital inputs, for cabinet tamper and battery status usage. A security controller provides 2 integral (onboard) reader inputs. Depending on security controller model, additional SEC-H-R2R/U modules can be added, to support a total of:

- SEC-H-602: If using 2 on-board reader inputs, license expansion packs required for any SEC-H-R2R/U modules.
- SEC-H-616: Standard license for up to 16 readers: up to seven (7) SEC-H-R2R/U modules plus 2 on-board readers. Additional readers are supported with purchase and installation of license expansion packs.

**NOTE: License expansion reader packs are available in eight (8) reader packs: Part Number SEC-8-RDR.**

For the SEC-H-602 and the SEC-H-616, each license expansion pack allows 8 readers (four SEC-H-R2R/U modules). A maximum of 15 total expansion modules (of any kind) are allowed; thus a fully expanded SEC-H-602 or SEC-H-616 supports 32 readers.

The SEC-H-R2R/U module uses DIN rail mounting, and has two end-mounted 6-pin connectors that support direct-chaining (in-line attachment) to other expansion modules. Alternatively, you can mount the SEC-H-R2R/U module onto a different DIN rail, and wire the assemblies together via 6-position connector plugs. This lets you locate multiple assemblies of expansion modules, either in the same or remote WEBS-AX Security Enclosures.



The security controller communicates to the SEC-H-R2R/U module (and other expansion modules) using RS-485 multidrop on 3 wires of the 6-terminal module bus. The other 3 wires of the module bus provide primary DC power for normal operation, as well as battery backup power for power-lost scenarios.

## Related Documentation

For more information on mounting and wiring a WEBS-AX Security system, refer to the following documents:

- Security Controller (SEC-H-600/U) Installation Instructions, Form Number 95-7759
- Security Controller (SEC-H-201/U) Installation Instructions, Form Number 95-7750
- SEC-H-602 and SEC-H-616 Security Controller Installation Instructions, Form Number 31-00012
- Remote I/O Module (SEC-H-RIO/U) Installation Instructions, Form Number 74-4060
- Medium (SEC-ENC-H-1/U or SEC-ENC-H-1NP/U) and Large (SEC-ENC-H-2/U or SEC-ENC-H-2NP/U) Security Enclosure Install Guide, Form Number 95-7747
- Small (SEC-ENC-H-3/U) Security Enclosure Install Sheet, Form Number 95-7748.

For software configuration details on a functioning system, refer to the *WEBS-AX Enterprise User's Guide*, Form Number 74-4086.

## PREPARATION

Unpack the SEC-H-R2R/U module and inspect the contents of the package for damaged or missing components. If damaged, notify the appropriate carrier at once, and return for immediate replacement (see Returning a Defective Unit, page 22). See the next sections Included in this Package and Material and Tools Required.

### Included in this Package

Included in this package you should find the following items:

- a Remote 2 Reader Module (SEC-H-R2R/U).
- this document *Remote 2 Reader Module (SEC-H-R2R/U) Installation Instructions*, Form Number 95-7749.
- a hardware bag containing the following items:
  - Five (5) pin-mount, screw-terminal connectors (two 7-position, two 6-position, one 3-position) for connection of readers, relay outputs, supervised inputs, and digital inputs. For more details, see About Screw Terminal Connectors, page 6.
  - One (1) grounding wire, with quick-disconnect 0.187" female connector.
  - 4 end-of-line resistor packs (four leads each) for installation at contacts wired to supervised inputs.
  - One (1) 6-position screw terminal end-plug, for usage if the SEC-H-R2R/U is not mounted in-line with another module with this end-plug. For wiring RS-485 communications, and typically battery backup.

### Material and Tools Required

The following supplies and tools are required for installation:

- WEBS-AX Security Enclosure, model SEC-ENC-H-1/U, SEC-ENC-H-1NP/U, SEC-ENC-H-2/U, SEC-ENC-H-2NP/U, or SEC-ENC-H-3/U. Enclosures include a door with key lock and tamper switch, and interior 35mm DIN rail(s) for mounting modules.
- Approved 12–15Vdc power supply source and 12Vdc backup battery source, provided by either:
  - Direct attachment in the security controller controller's SEC-ENC-H-2/U enclosure.
  - Using integral 30W 15Vdc power supply of another SEC-ENC-H-1/U or SEC-ENC-H-2/U enclosure, or by mounting in a non-powered Security Enclosure (SEC-ENC-H-1NP/U, SEC-ENC-H-2NP/U, SEC-ENC-H-3/U), with 15Vdc power wiring ("PS-", "PS+") connected back to the power supply in an SEC-ENC-H-1/U or SEC-ENC-H-2/U enclosure. In any case, battery backup wiring ("PS-", "BB") to the enclosure with security controller is needed.
  - Third party, 12Vdc power supply, with integral battery-backup. Only certain models have UL 294 approval. See Battery-backed Power Supplies, page 21.
- Suitable tools and supplies for mounting SEC-H-R2R/U module, and for making all wiring terminations.

## PRECAUTIONS

This document uses the following warning and caution conventions:



### CAUTION

Cautions remind the reader to be careful. They alert readers to situations where there is a chance that the reader might perform an action that cannot be undone, might receive unexpected results, or might lose data. Cautions contain an explanation of why the action is potentially problematic.



### WARNING

Warnings alert the reader to proceed with extreme care. They alert readers to situations where there is a chance that the reader might do something that can result in personal injury or equipment damage. Warnings contain an explanation of why the action is potentially dangerous.

## Safety Precautions

The following items are warnings of a general nature relating to the installation and start-up of an security controller. Be sure to heed these warnings to prevent personal injury or equipment damage.



### WARNING

A 15Vdc circuit powers the SEC-H-R2R/U module and attached security controller. Disconnect power before installation or servicing to prevent electrical shock or equipment damage.

Make all connections in accordance with national and local electrical codes. Use copper conductors only.

To reduce the risk of fire or electrical shock, install in a controlled environment relatively free of contaminants.

Controllers and I/O modules are only intended for use as monitoring and control devices. To prevent data loss or equipment damage, do not use them for any other purposes.

## Static Discharge Precautions

The following items are cautionary notes that will help prevent equipment damage or loss of data caused by static discharge.



### CAUTION

Static charges produce voltages high enough to damage electronic components. The microprocessors and associated circuitry within a Remote 2 Reader Module are sensitive to static discharge. Follow these precautions when installing, servicing, or operating the system:

Work in a static-free area.

Discharge any static electricity you may have accumulated. Discharge static electricity by touching a known, securely grounded object.

Do not handle the printed circuit board (PCB) without proper protection against static discharge. Use a wrist strap when handling PCBs, with the wrist strap clamp secured to earth ground.

## Module Connection Precautions



### CAUTION

Avoid "hot" plug-in or removal of any expansion module from the security controller (or other expansion module), whenever a system is operational.

Do not connect more than 15 SEC-H-R2R/U modules to a single SEC-H-602 or SEC-H-616 security controller.

This is the maximum number of SEC-H-R2R/U modules supported in software.

# INSTALLATION AND START-UP OUTLINE

**NOTE:** If installing the security controller and SEC-H-R2R/U module at the same time, please refer to the appropriate *Security Controller (model) Installation Instructions* document to install the SEC-H-602 or SEC-H-616 controller.

The major steps to installing and starting the SEC-H-R2R/U module are outlined as follows:

1. Physically mount the SEC-H-R2R/U module onto DIN rail. See Physical Mounting below. If directly attaching to other modules, ensure that the 6-position end connector(s) are properly seated into the end connectors of the other units. Note the previous Module Connection Precautions, page 3.
2. Make wiring connections for grounding, security I/O wiring, and power. See Wiring Overview, page 7.
3. Apply power and perform an initial checkout. See Power Up and Initial Checkout, page 20.

## PHYSICAL MOUNTING

Mount the SEC-H-R2R/U module in a WEBS-AX Security Enclosure only (model SEC-ENC-H-1/U, SEC-ENC-H-1NP/U, SEC-ENC-H-2/U, SEC-ENC-H-2NP/U, or SEC-ENC-H-3/U). See the enclosure installation documents listed in Related Documentation, page 2.

**NOTE:** All U.S. Installations: For a UL Listed system (UL 294) you must mount the Remote 2 Reader Module (SEC-H-R2R/U) in a WEBS-AX Security Enclosure, as well as the security controller and any other expansion modules. If installed in any other enclosure (even one with the same listing), UL listings are voided! Also refer to UL Requirements, page 21.

Note that if mounting in an enclosure with integral power supply (SEC-ENC-H-1/U or SEC-ENC-H-2/U), you can plug it into the enclosure's power supply, or (if already occupied) into another assembly of modules already mounted. See Fig. 1, page 5. It is not necessary to remove the cover before mounting.

### Step-by-step instructions for mounting the SEC-H-R2R/U module on an installed DIN rail.

1. Position the SEC-H-R2R/U module on the rail, tilting to hook DIN rail tabs over one edge of the DIN rail (Fig. 1).
2. Use a screwdriver to pry down the plastic locking clip, and push down and in on the SEC-H-R2R/U, to force the locking clip to snap over the other edge of the DIN rail.
3. Slide the SEC-H-R2R/U module along the DIN rail to its intended location, as one of the following:
  - If left-most module on the top rail of an SEC-ENC-H-1/U or SEC-ENC-H-2/U enclosure, seat its 6-position plug into power supply socket, such that its mounting-tab holes align with tapped holes in the enclosure.
  - If left-most module on the lower rail of an SEC-ENC-H-2/U or SEC-ENC-H-2NP/U enclosure, slide it to the far left, such that its mounting-tab holes align with tapped holes in the enclosure.
  - If connecting to another module already mounted and secured, seat its 6-position plug into that module's connector socket, such that mounting-tab holes align with tapped holes in the enclosure.

In any case, note that the holes in the two plastic mounting tabs of the SEC-H-R2R/U module should be aligned with the tapped holes in the back of the enclosure.

4. Install supplied screws through the mounting tab holes into the enclosure holes, and tighten.
5. Repeat this for all items, until all are mounted on the DIN rail(s), firmly connected to each other, and secured with mounting tab screws.

Fig. 1. Remote 2 Reader Module mounting details.

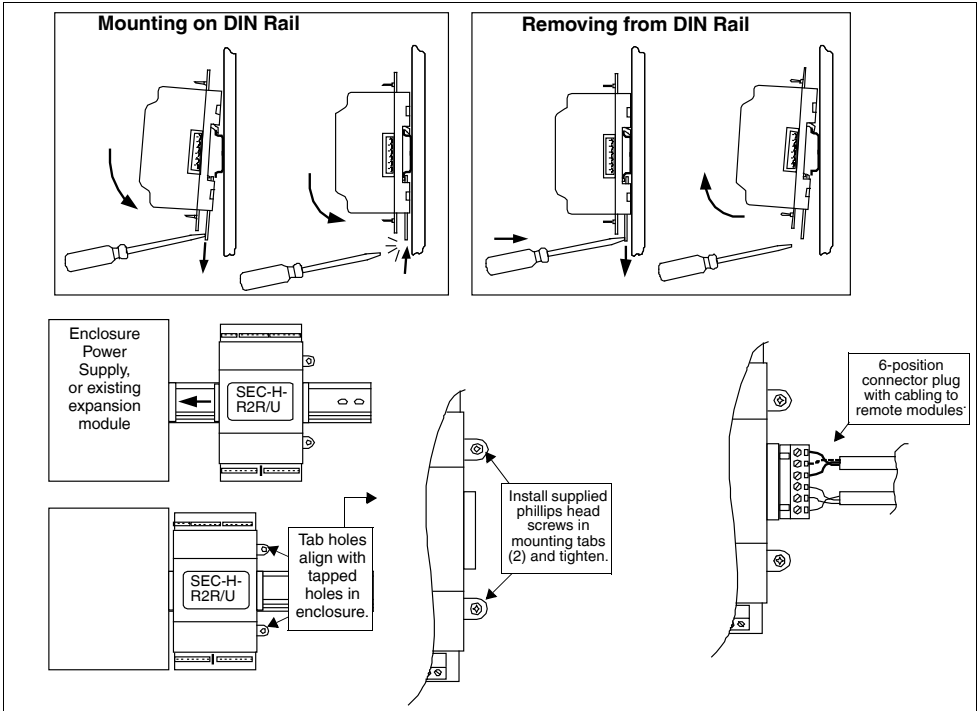

**NOTE:** To remove a SEC-H-R2R/U module from DIN rail, remove the two mounting tab screws and slide it away from other modules. Insert a screwdriver in the center plastic locking tab and pull downwards, then lift the unit outwards.

# SEC-H-R2R/U BOARD LAYOUT AND TERMINAL LOCATIONS

The SEC-H-R2R/U module provides 2 Reader Inputs, 4 Supervised Inputs, 2 Relay Outputs, and 2 (unsupervised) Digital Inputs. Wiring terminal positions are shown below (Fig. 2), along with LED locations.

**Fig. 2. Remote 2 Reader Module Wiring Terminal Locations (screw terminal connectors removed).**

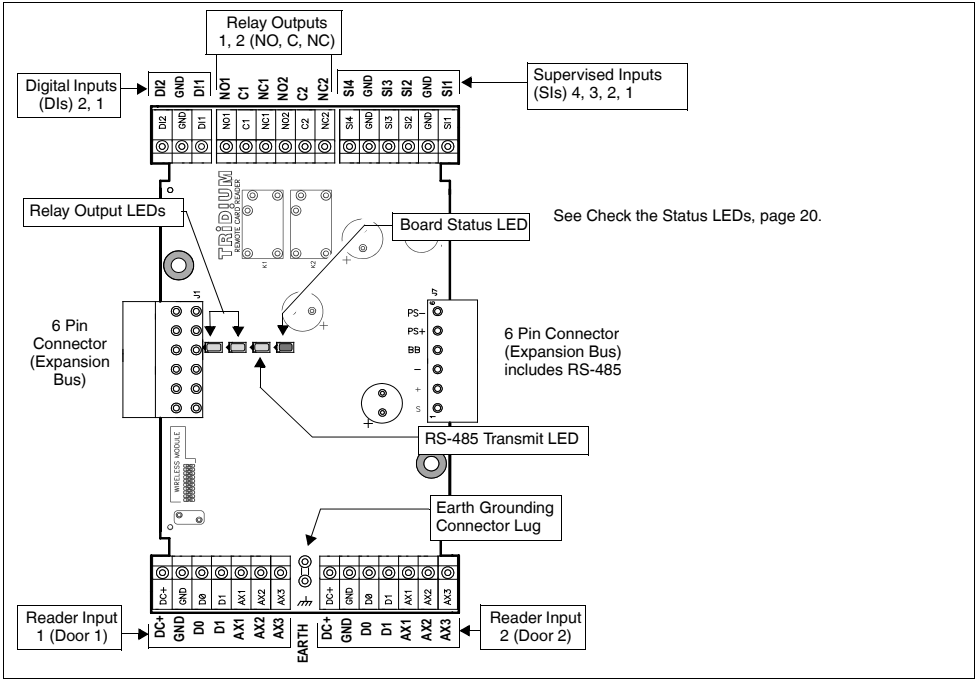

## About Screw Terminal Connectors

Screw-terminal connectors are shipped loose in a separate hardware bag. If desired, you can make wiring terminations to connectors *before* installing on the SEC-H-R2R/U circuit board pins. Please note the following:

- If you install a connector onto the board pins, terminal labels (on the circuit board) are *covered*.
- Removal of larger connectors (readers, relay outputs) may be difficult, especially if wiring has been landed. Here, removal is recommended only if replacing the device.

In general, it may be easiest to wire to *loose* connectors (held next to pins), then install them after completing.

# WIRING OVERVIEW

The following sections provide general wiring information:

- General Wiring Rules
- Connection Overview
- Grounding
- Cable Types and Lengths

## General Wiring Rules

The authorized installation contractor should comply with the following rules:

- Obey all national, state, and local electrical and safety codes.
- Obtain any required permits and/or inspections. Contact the local fire marshal for assistance, if necessary.
- Connect the enclosure housing the Remote 2 Reader Module to the nearest earth ground.
- Use individually shielded pairs of cable only. All wiring must comply with local, state, and federal electrical codes and fire codes.



### CAUTION

Do not run signal wiring in same conduit with AC power wiring.

- Neatly label cables at both ends.  
For example, label should include: Remote 2 Reader Module terminal #s/Device or Reader #.
- Neatly dress and tie or lace all wiring in a professional manner.
- Gather together and tape all unused conductors in multiple conductor cables.
- Ground all shield drain wires at the enclosure, using crimp ring terminals fastened to internal grounding studs/ screws or with external screws and star washers. See Fig. 3.  
At the *other end* of shielded cables, *leave shield drain wires open*, either taping back or insulating to prevent electrical contact.

**Fig. 3. Ground All Shielded Cable/Drain Wires at Enclosure, Either Internally (Left) or Outside (Right).**

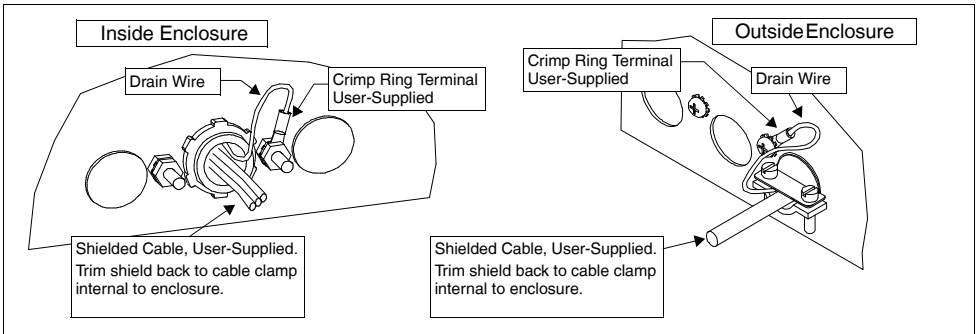

## Connection Overview

See Fig. 2, page 6 to locate connectors and other components on the Remote 2 Reader Module. Make connections to the SEC-H-R2R/U module in the following order.

1. Connect the earth grounding wire to a nearby earth grounding point. See Grounding for details.
2. Connect wiring to door readers, door strikes, door switches, and any other security I/O to the SEC-H-R2R/U. See Security I/O Wiring, page 9. If other expansion modules are being installed, make similar security I/O connections to these devices. Refer to the appropriate Installation Instructions.
3. Connect RS-485 communications wiring. See RS-485 Communications, page 16.
4. Prepare power wiring (leave the unit powered off). See Power and Backup Battery, page 17 for details.
5. Apply power to the SEC-H-R2R/U module, and if not already powered, to the security controller. See Power Up and Initial Checkout, page 20.

## Grounding

Connect the supplied earth grounding wire to the ground spade lug (0.187") on the SEC-H-R2R/U module, and the other end to a nearby earth ground (see Fig. 4). Keep this wire as short as possible.

**Fig. 4. Connect earth ground using supplied grounding wire to grounding lug.**

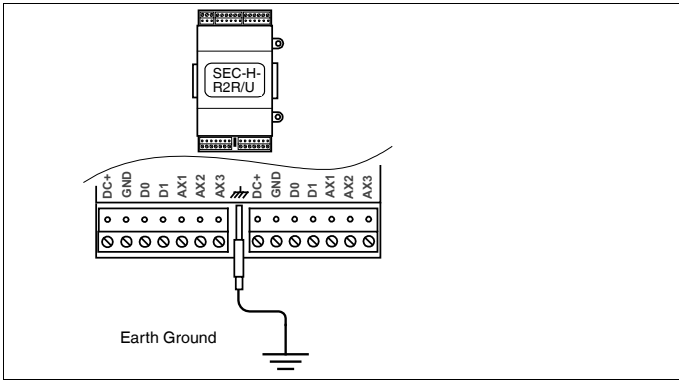

In addition, connect the earth grounding lug of *each expansion module* to earth ground in the same manner.

## Cable Types and Lengths

Recommended cable types and maximum lengths are as follows:

- RS-485 Communications between the security controller and expansion modules (including the SEC-H-R2R/U), use a 24 AWG shielded, twisted pair communication cable with low capacitance (Belden #9501 or equivalent). Maximum length is 4000 feet (1220m).
- Reader Inputs use Belden #8725 (4-pair) or #8723 (2-pair) or equivalent. Maximum length 500 feet (152m).
- Supervised Inputs and Digital Inputs use a 22 AWG shielded, twisted pair cable control cable (Belden #9461 or equivalent). Maximum length 2000 feet (610m).
- Relay Outputs use 18 AWG unshielded instrumentation cable (Belden #9740 or equivalent), maximum length is 2000 feet (610m). Relay outputs are rated for a maximum load of 3.0A.
- For lengths between different enclosures: Battery Backup cabling (PS-, BB): a single pair (2-conductor) shielded cable. If mounting in a non-powered Security Enclosure (SEC-ENC-H-1NP/U, SEC-ENC-H-2NP/U, or SEC-ENC-H-3/U), the "Trunk power" cabling (PS-, PS+, BB) requires a "triad" type (3 conductor) shielded cable, such as Belden #1031A (14AWG), or equivalent. Maximum distances vary, see the *Security Controller (model) Installation Instructions* for more details.



# SECURITY I/O WIRING

Security I/O wiring is covered in the following subsections:

- Door Terminal Associations, page 9
- Reader Input, page 10
- Supervised Input, page 12
- Relay Output, page 14
- Digital Input, page 15

## Door Terminal Associations

The SEC-H-R2R/U module provides access control for two doors. For each door, the module *allocates*:

- One Reader Input (for a Wiegand-type, 12V reader)
- Two Supervised Inputs: one for door switch monitor, one for REX (request-to-exit)
- One Relay Output: for door strike control.

An enforced convention is used for the logical association between reader inputs, supervised inputs, and relay outputs for each door, as shown in Table 1.

**Table 1. Door mapping to security I/O terminal points.**

Door	Reader Input	Supervised Input Terminals (with GND)		Relay Output Terminals Door Lock
		Door Switch Monitor	Request to Exit (REX)	
Door 1	Card Reader 1	SI1	SI2	1 (C1 and NO1, or NC1)
Door 2	Card Reader 2	SI3	SI4	2 (C2 and NO2, or NC2)

**NOTE:** Terminal associations shown in Table 1 also apply if wiring a security controller.

See the following sections for more details:

- Example Door 1 Wiring
- Other Terminal Associations

## Example Door 1 Wiring

Fig. 5 below shows a SEC-H-R2R/U wiring schematic for a door with an HID-type reader, normally-closed door contact, normally-closed exit (REX) device, and a DC door strike controlled by a normally-open relay.

Fig. 5. Example Door 1 wiring

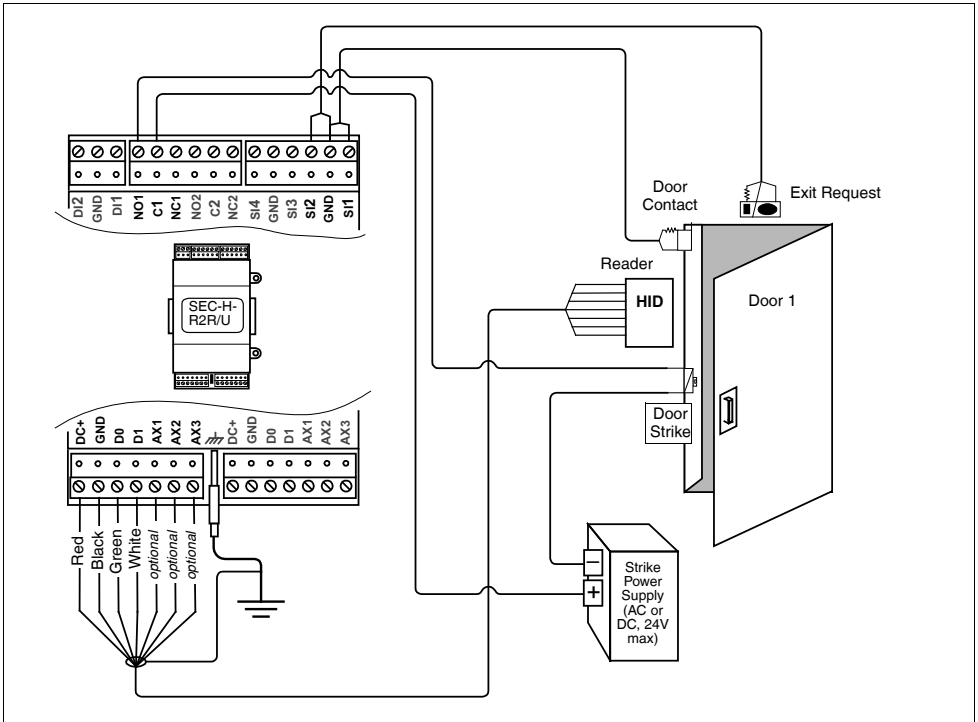

## Other Terminal Associations

In addition to the pre-allocated I/O for Door Terminal Associations, the SEC-H-R2R/U module has two unsupervised digital inputs. See Digital Input, page 15.

## Reader Input

The SEC-H-R2R/U module has two door reader inputs, each supporting a Wiegand-type 12Vdc reader. Two 7-position input connectors are the same side of the SEC-H-R2R/U board, separated by the earth ground lug. See Fig. 6. Pinouts for each card reader connector are shown in Table 2.

**NOTE:** A door wired to a reader input has other I/O points, see Door Terminal Associations, page 9.

Fig. 6. Reader wiring to SEC-H-R2R/U expansion module.

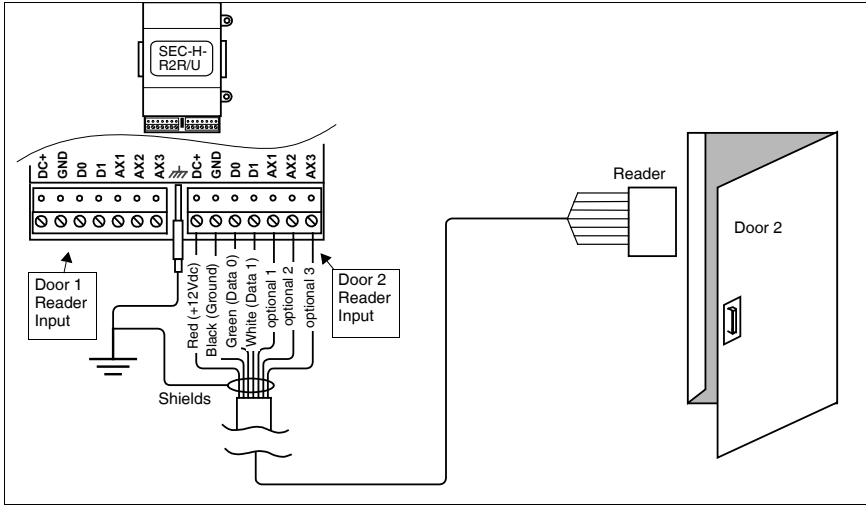

Table 2. Pinouts for Card Reader Inputs

Terminal	Terminal Name	Terminal Notes	Typical cabling colors
DC+	+12Vdc to Reader	Always wire these four terminals to the corresponding reader terminals.	Typically Red wire.
GND	Ground		Typically Black wire.
D0	Reader Data 0		Typically Green wire.
D1	Reader Data 1		Typically White wire.
AX1	Auxiliary 1	Optional, wire to reader's <b>Green LED control</b>	At reader, typically Orange wire.
AX2	Auxiliary 2	Optional, wire to reader's <b>Red LED control</b>	At reader, typically Brown wire.
AX3	Auxiliary 3	Optional, wire to reader's <b>Beeper control</b>	At reader, typically Blue or Yellow wire.

## Reader Wiring Notes

- Mount the reader, referring to the specific manual for that reader for instructions.
- Use shielded, twisted-pair, cabling (Belden #8725 or #8723 or equivalent, as needed) to connect the reader to the SEC-H-R2R/U. Maximum cable distance is 500 feet (152m).
- Run this cabling from the reader to the SEC-H-R2R/U, bringing it through an appropriate knockout in the enclosure used. Allow sufficient slack cable for servicing.
- Tie all shield wires together, and connect to the designated grounding point at the enclosure. See Fig. 3, page 7.
- Place the appropriate wires in the appropriate screw terminals of the 7-position reader connector. Refer to the pinouts in Table 2 for reader input designations. Fig. 6 shows typical wiring colors.

## Supervised Input

The SEC-H-R2R/U module has four (4) supervised inputs, with terminals on a 6-pin connector located next to the relay outputs (see Fig. 7).

**NOTE: Supervised inputs are intended for Door 1 and 2 usage. See Door Terminal Associations, page 9.**

Under the connector, terminals are labeled SI4, GND, SI3, SI2, GND, SI1. This means when wiring, *two* conductors are typically landed to each GND terminal. Each supervised input can monitor dry contacts, either normally-open (N.O.) or normally-closed (N.C.).

One End-of-Line Resistor Pack is required at the monitored contacts for each input, for proper operation. Fig. 7 shows wiring of supervised inputs SI1 and SI2, which are reserved for Door 1 usage.

**Fig. 7. Supervised input wiring to Remote 2 Reader Module.**

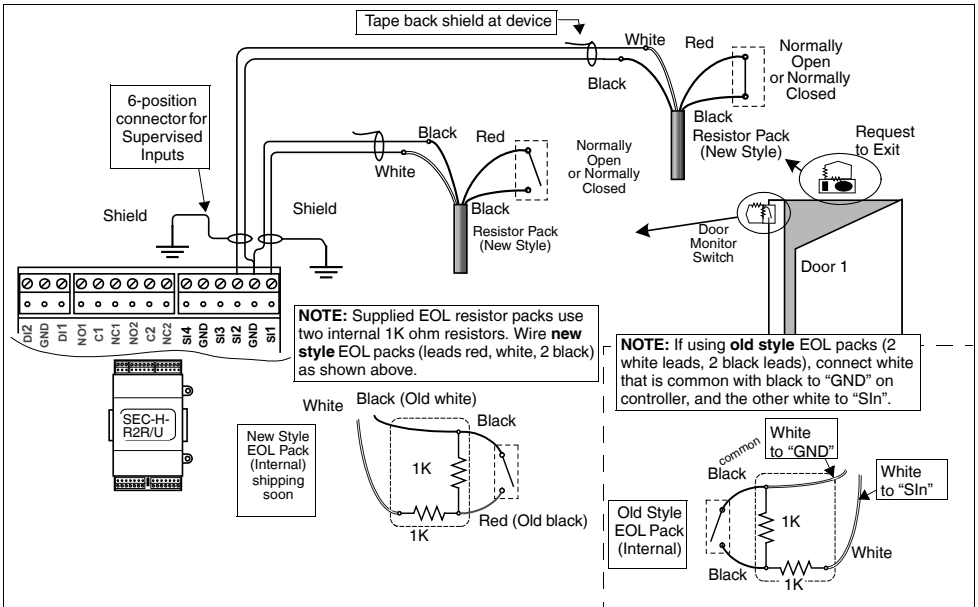

## End-of-Line Resistor Pack

You must install an end-of-line (EOL) resistor pack at the monitored device for proper operation. Four (4) EOL resistor packs are shipped with each Remote 2 Reader Module. Each resistor pack has four leads:

- New style (shipping soon): One red, one white, two black leads. Wire as shown in Fig. 7.
- Old style: Two white, two black leads. Wire black leads across contacts, and wire the white lead shown internally connected to the black lead (common) to the "GND" input, and the other white lead to the "SIn" input. See the detail in lower right of Fig. 7.

Install each EOL resistor pack as close as possible to the actual monitored switch/contacts.

## Supervised Input Wiring Notes

- The device monitored by a supervised input should have dry contacts (voltage free) as either a normally-open or normally-closed type switch. Mount the device per the vendor's instructions.
- Use shielded, twisted-pair cabling to connect the device to the SEC-H-R2R/U. Maximum cable distance is 2000 feet (610m).
- Run this cabling from the device to the SEC-H-R2R/U, bringing it through an appropriate knockout in the enclosure used. Allow sufficient slack cable for servicing.
- At the device, connect the cable by installing one of the supplied 4-lead EOL resistor packs. Install this resistor pack as close as possible to the device's contacts.  
Depending on **new** or **old style** EOL resistor pack, wire the EOL leads by color. See Fig. 7, page 12.

- If a **new style** EOL pack, wire the red lead and either black lead across the monitored contacts, and wire the white lead to the "SI $n$ " input, and the other black lead to the SI "GND" input.
- If an **old style** EOL pack, wire the black leads across the contacts, and wire the white lead shown internally connected to the black lead (common) to the "GND" input, and the other white lead to the "SI $n$ " input. Note you can use a multimeter to determine which of the two EOL pack white leads are common to one of the black leads.

Insulate the shield wire at the device by taping back or using shrink tubing.

- At the SEC-H-R2R/U, ground shield drain wires at the enclosure. See Fig. 3, page 7.
- Connect the two conductors from the device's contacts to the appropriate SI $n$  terminal and adjacent GND terminal. Note that supervised inputs on a SEC-H-R2R/U module have Door Terminal Associations.

## About Supervised Input States

Although monitoring a digital (two-state) device, each supervised input has four possible states:

- Shorted—A "trouble" state, meaning shorted input—supervision resistors cannot be detected.
- Closed—A "normal" state, meaning contacts closed, with supervision resistor(s) detected.
- Open—A "normal" state, meaning contacts open, with supervision resistor(s) detected.
- Cut—A "trouble" state, meaning an open input—supervision resistors not detected.

Each supervised input tests for the current state using a simple voltage divider, using a (fixed) 1.5K ohm onboard pull-up resistor, and the resistance (R) value of the monitored device, where

$$\text{Input \%} = R / (R + 1500)$$

$$0\% - 17\% = 0 \text{ (shorted wires) to } 300$$

$$17\% - 50\% = 300 \text{ to } 1500 \text{ (Closed)}$$

$$50\% - 83\% = 1500 \text{ to } 7500 \text{ (Open)}$$

$$83\% - 100\% = 7500 \text{ to infinite (cut wires)}$$

## Relay Output

The SEC-H-R2R/U module has two (2) Form-C relay outputs, each rated to switch 24VAC/DC loads up to 3A. Output terminals are on a 6-position connector between the digital inputs and supervised inputs (see Fig. 8). Terminals are labeled 1 or 2; each has a NO $n$ , C $n$ , NC $n$  position—for example NO2, C2, NC2 for output 2. An LED for each output is on the circuit board; these LEDs are also visible when the cover is on the module.

**NOTE:** Relay outputs 1 and 2 are reserved for Door 1 and Door 2 strike control, respectively. For more details, see **Door Terminal Associations, page 9.**

## Door Strike Wiring

Typical door strike wiring, in this case for Door 1 using relay output 1, is shown in Fig. 8.

**Fig. 8. Relay output wiring from SEC-H-R2R/U to door strike.**

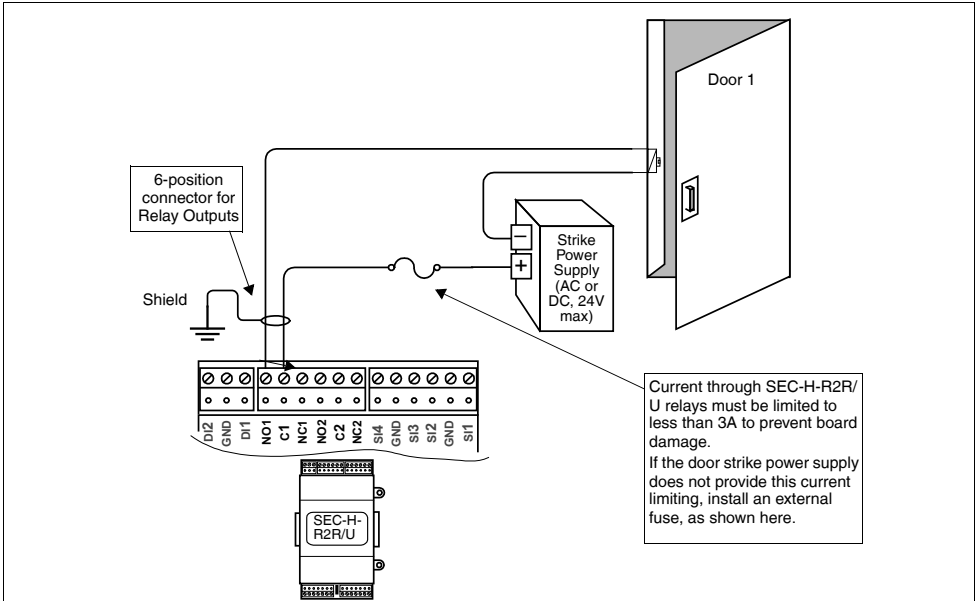

## Relay Output Wiring Notes

- Install the door strike or auxiliary output device per the vendor's instructions.
- Use shielded, twisted-pair cabling to connect the circuit to the SEC-H-R2R/U. Maximum cable distance is 2000 feet (610m)
- Wire the door strike or auxiliary output device to the appropriate relay output on the SEC-H-R2R/U and to the power supply used to power the strike or device. Each relay output on the SEC-H-R2R/U has a common terminal (C), and normally open (NO) and normally closed (NC) terminal.
- At the SEC-H-R2R/U, ground shield wires to the designated grounding point at the enclosure. See Fig. 3, page 7.

## Digital Input

The SEC-H-R2R/U has two (2) digital inputs, located on a 3-position connector next to the relay output connector (see Fig. 9). Under the connector, terminals are labeled DI2, GND, DI1. This means when wiring, as many as *two* conductors can be landed to the common GND terminal.

Each digital input can monitor dry contacts, either normally-open (N.O.) or normally-closed (N.C.). Both inputs are *unsupervised*—no end-of-line resistors are required. Fig. 9 shows example wiring to digital inputs.

**Fig. 9. Digital input wiring example to SEC-H-R2R/U module.**

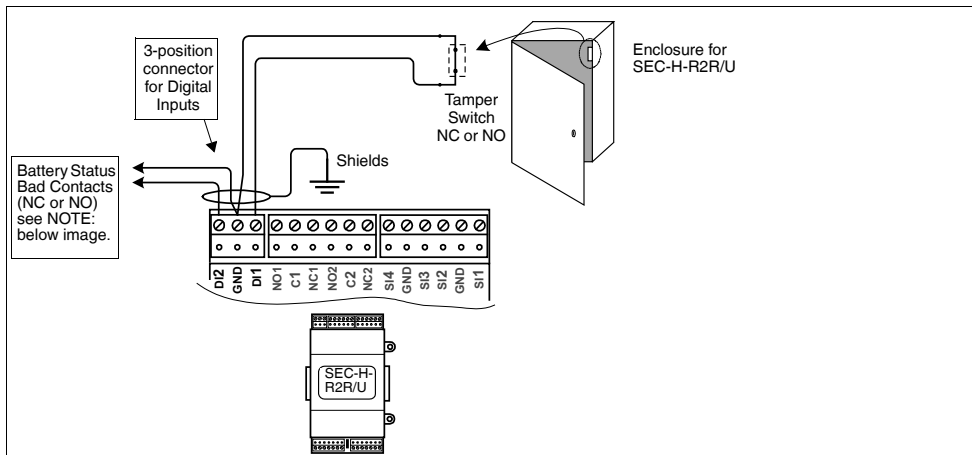

**NOTE:** The software application in the security controller is pre-configured to support the following connections:

**DI1 — Tamper switch (typically for enclosure door)**

**DI2 — Battery status bad (if contacts available)**

Depending on the installation, not all DIs may require connection. In particular, input DI1 is wired only if no other module (or security controller) has the same input wired to the enclosure door tamper switch—only one is needed per enclosure. Input DI2 is typically wired only if the SEC-H-R2R/U module is in a remote assembly of modules, where a Third-party Battery-Backed Power Supply is used, and it has “battery bad” contacts. Here again, only one such input is needed to be wired per enclosure.

## Digital Input Wiring Notes

- The device monitored by a digital input should have dry contacts (voltage free) as either a normally-open or normally-closed type switch. Mount the device per the vendor’s instructions.
- Use shielded, twisted-pair cabling to connect the device to the SEC-H-R2R/U. Maximum cable distance is 2000 feet (610m).
- Run this cabling from the device to the SEC-H-R2R/U, bringing it through an appropriate knockout in the enclosure (if applicable). Allow sufficient slack cable for servicing.
- At the device, connect its contacts to the cable pair, and insulate the shield wire by taping it back or using shrink tubing.
- At the SEC-H-R2R/U, ground shield wires to the grounding point at the enclosure. See Fig. 3, page 7.
- Connect the two conductors from the device’s contacts to the appropriate DI $n$  terminal and common GND terminal. Note that the software expects DIs to monitor specific items—see previous NOTE above.

## RS-485 COMMUNICATIONS

An RS-485, optically isolated port is dedicated for communications to the security controller, on pins 1, 2, and 3 of the 6-position end connectors. Wiring is not necessary between modules that attach directly in-line together—the RS-485 signal passes through the mated connectors.

Wire between device assemblies using the 6-position end connector plugs. Use shielded 18-22AWG wiring (refer to the TIA/EIA-485 standard). Wire in a continuous multidrop fashion, meaning “plus to plus,” “minus to minus”, and “shield to shield.” Connect the shield to earth ground at one end only, such as at the security controller. See Fig. 10 for example cabling.

**Fig. 10. RS-485 cabling between the security controller and expansion modules not mounted in-line.**

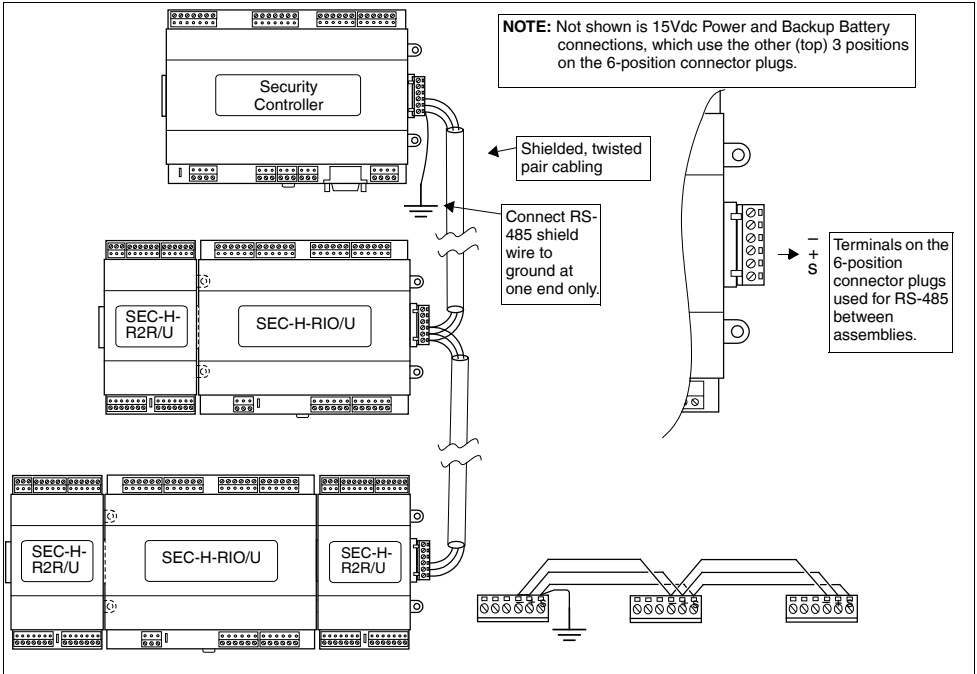

### RS-485 Wiring Notes

- Use shielded, twisted-pair, low-capacitance type cabling to connect expansion modules on the RS-485 trunk. Maximum cable distance is 4000 feet (1220m).
- At the security controller, ground the shield wire to the grounding point at the enclosure. See Fig. 3, page 7. Leave the shield wire at the other end of the trunk open, meaning insulate the shield wire by taping it back or using shrink tubing.
- If connecting assemblies of modules within the same enclosure, or between adjacent enclosures (same location), you can use a multi-pair, shielded, twisted-pair cable, for both the RS-485 and 15Vdc power and battery backup.



## POWER AND BACKUP BATTERY

The SEC-H-R2R/U module must be powered by an approved, regulated, 12–15Vdc power source. This can be *either* of the following:

- The 30W 15Vdc Enclosure Power Supply in an SEC-ENC-H-1/U or SEC-ENC-H-2/U enclosure.
- A Third-party Battery-Backed Power Supply, with UL 294 approval. Typically, this option is used only if the SEC-H-R2R/U module is located a long distance from the security controller, such that running backup battery power from the security controller results in too much voltage drop.

**NOTE:** Door strike power, as well as power for other loads switched by the SEC-H-R2R/U, security controller, and any other expansion modules, should always be provided from a different source.

In addition, wiring to the backup battery (“BB”) output of the security controller is required, to allow system operation during AC power outages. The sole exception to this is if the SEC-H-R2R/U module is powered by a Third-party Battery-Backed Power Supply. Refer to the *Security Controller (model) Installation Instructions* section “System Planning” for related details, and also to Power and Backup Battery Wiring Notes, page 20.



### WARNING

De-energize the circuit powering the Vdc supply before making wiring connections to the end connector plug.



### CAUTION

Do not apply power to the system until all other mounting and wiring is completed. See Power Up and Initial Checkout, page 20.

## Enclosure Power Supply

The integral power supply in an SEC-ENC-H-1/U or SEC-ENC-H-2/U enclosure provides 30W of regulated 15Vdc power to an security controller and housed expansion modules. Input voltage is 120Vac to 240Vac, single phase, with line connections under a metal shield. Output from the power supply is on a 6-position connector socket, aligned with a DIN rail in the enclosure. The security controller plugs directly into this socket for power.

For larger jobs, multiple SEC-ENC-H-1/U and/or SEC-ENC-H-2/U enclosures may be used, where only one enclosure contains the security controller (plus some expansion modules)—additional enclosures may house (and power) more expansion modules.

The two methods of wiring power between multiple enclosures are as follows:

- Single Power Supply, page 17
- Multiple Power Supplies, page 18

## Single Power Supply

If the job is designed with a single power supply, you wire the 3 conductors “PS-”, “PS+”, “BB” from the enclosure with the security controller, to all other expansion modules. Within the same SEC-ENC-H-2/U enclosure, this connection is made by the supplied “6-wire harness” to connect assemblies on the two DIN rails.

Between enclosures, use a “triad” type (3 twisted conductor) cable of the appropriate gauge, with the shield wire grounded at one end only. Fig. 11 shows wiring when using a single power supply for 4 different assemblies (3 enclosures), including a Security Controller and multiple SEC-H-R2R/U modules in SEC-ENC-H-3/U enclosures.

**Fig. 11. Single Power Supply to multiple and Backup Battery (BB) between security controller and expansion modules.**

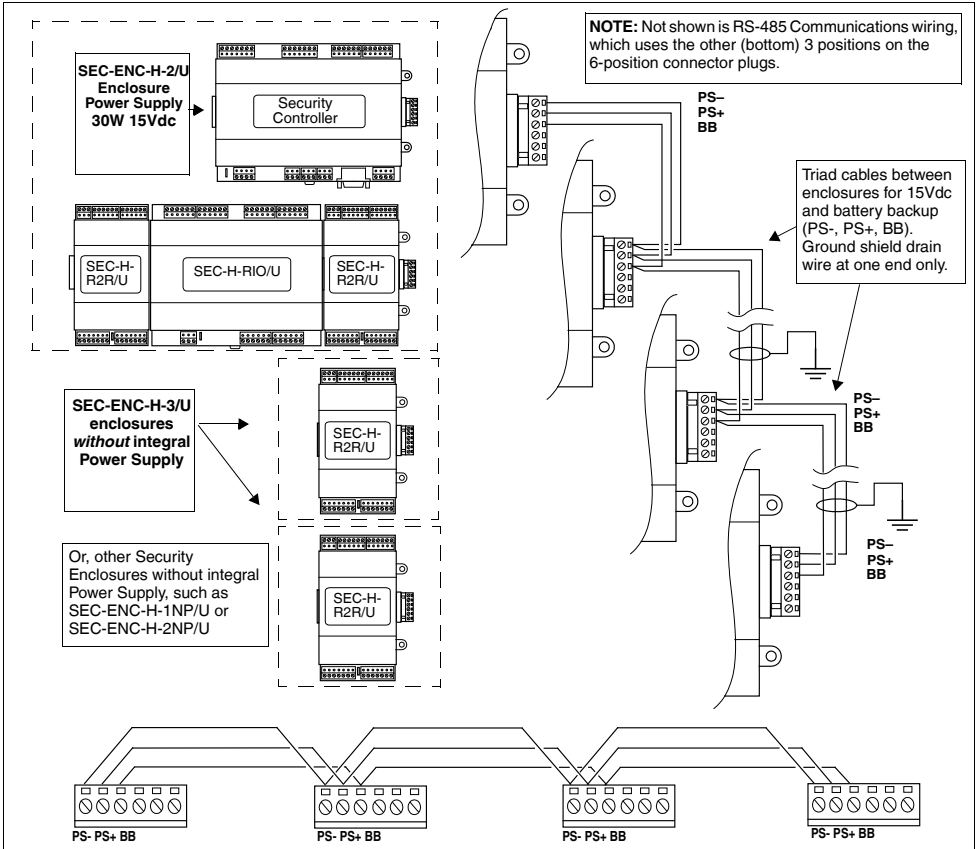

Note the "BB" terminal from the security controller provides 12Vdc power from the backup battery (at a *maximum 2.5A load*), upon loss of primary 15Vdc power. Backup power is "switched" by the security controller. This means when running on backup battery power, upon draining the sealed-lead acid backup battery, the security controller performs a shutdown and powers *off* all connected expansion modules (and any attached readers).

**Multiple Power Supplies**

If the job is designed with multiple WEBs-AX Security Enclosures with integral power supplies, you can wire only 2 conductors "PS-" and "BB" between the enclosures, using a twisted pair cable of the appropriate gauge, and the shield wire grounded at one end. Fig. 12 shows two enclosure power supplies used for 4 different assemblies (2 different enclosures). Within each enclosure, a 6-wire harness connects the two assemblies.

# ⚠ WARNING

The security controller is limited to 2.5A output supply on PS+, PS-, BB, by a soldered (unreplaceable) fuse! Therefore, do exceed this output load on the security controller, even for battery backup purposes.

Fig. 12. Multiple Power Supplies with Backup Battery (BB) between security controller and expansion modules.

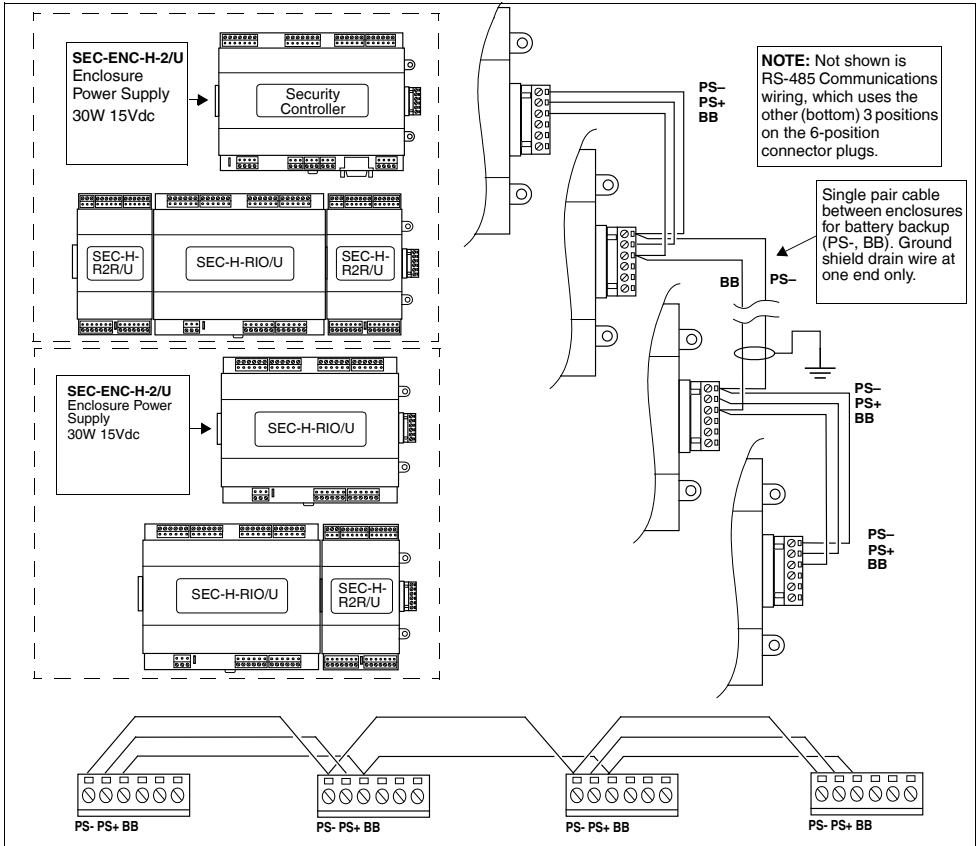

Again, note that the “BB” terminal from the security controller provides 12Vdc power from the backup battery (at a *maximum 2.5A load*), upon loss of primary 15Vdc power. Backup power is “switched” by the security controller. This means when running on backup battery power, upon draining the sealed-lead acid backup battery, the security controller performs a shutdown and powers *off* all connected expansion modules (and any attached readers).

## Third-party Battery-Backed Power Supply

In most systems, expansion modules (such as an SEC-H-R2R/U) get 15Vdc primary power and 12Vdc backup battery power by wiring to the Enclosure Power Supply and the “BB” terminal as shown in Fig. 11 or Fig. 12. However, in cases where the SEC-H-R2R/U module, and possibly other expansion modules, must be located *long distances* from the security controller (and its power supply/backup battery), cabling for the backup battery as shown in Fig. 12 may be impractical due to the voltage drop introduced.

**NOTE:** Refer to the *Security Controller (model) Installation Instructions* section “Voltage Drop Considerations.”

In this case, you can power the expansion module(s) using a third-party, UL 294 approved, battery-backed 12Vdc power supply, installed at a nearby location. Fig. 13 shows a wiring example.

Fig. 13. Third-party 12Vdc, battery backed, power supply powering expansion modules.

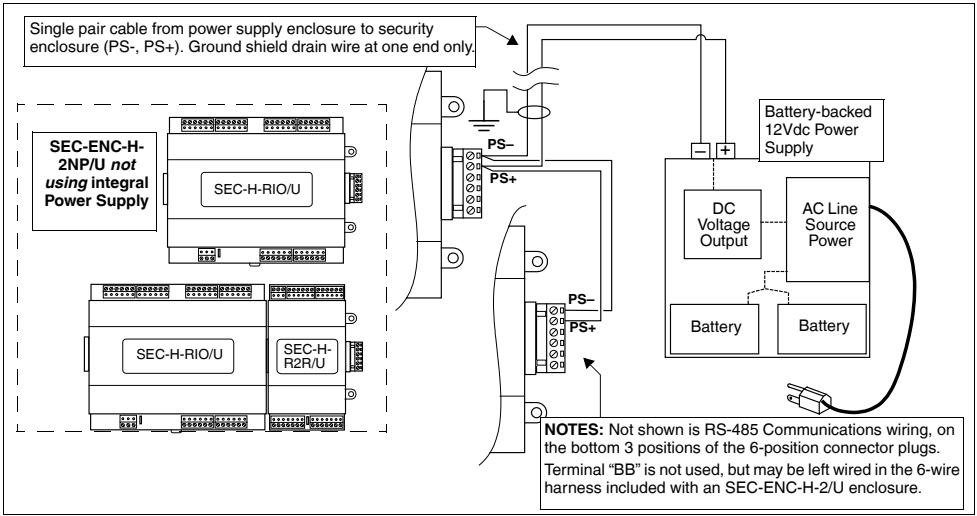

**NOTE:** Power must be regulated to within  $\pm 4\%$ .

The power supply and its enclosure must be UL 294 approved. See the UL Requirements section Battery-backed Power Supplies, page 21.

Only remote expansion modules can be powered by a 12Vdc power supply—the security controller requires 15Vdc furnished by the security Enclosure Power Supply. See the Security Controller (model) Installation Instructions document for details.

## Power and Backup Battery Wiring Notes

- Refer to the Security Controller (model) Installation Instructions document for planning details about estimating power supply and battery backup capacity for the various components in a WEBS-AX Security System. It is important to properly size the system's power supply and backup batteries. In a system with distributed expansion modules, cable selection for interconnecting module assemblies is also important.
- If connecting assemblies of modules within the same enclosure, or between adjacent enclosures (same location), a multi-pair, shielded, twisted-pair cable can be used for wiring all 6 positions of the end connector plugs. For example, use Belden #8725 (4-pair) 20 AWG "reader type" cable.

In this case, connect the RS-485 on one pair (including its shield wire), 15Vdc ("PS-" and "PS+") on a second pair, and battery backup ("BB") using a conductor of a third pair. In this case, wiring distances are short, and "voltage drop" considerations can be safely ignored.

## POWER UP AND INITIAL CHECKOUT

Ensure power wiring to the SEC-H-R2R/U module and other components is ready—see Power and Backup Battery, page 17. Following all mounting and wiring, perform the following:

### Initial power up and checkout

1. Apply Power.
2. Check the Status LEDs.

## Apply Power

Apply power to the SEC-H-R2R/U by energizing the connected Enclosure Power Supply, or by inserting the 6-position end connector plug (wired to power supply) into the module assembly with the SEC-H-R2R/U.

## Check the Status LEDs

See Fig. 2, page 6 for location of LEDs. When power is applied, the green LED labeled "STATUS" on the SEC-H-R2R/U will begin blinking about 2 times a second. Any blinking indicates that the module has power, but is not communicating with the parent security controller. The duty cycle of the status LED blink varies:

- A low duty cycle blink (rapid flash) means that the unit is *unconfigured* (no address assigned). A "discover" is needed, using the WEBS-AX Enterprise Security or Appliance system.

- A 50% duty cycle blink (equal time on and off) of the status LED means that the module is configured, but is currently *offline* with the security controller. Check that the RS-485 wiring between the module and security controller is ok, and that the security controller is powered on.

Following expansion module discovery and addition to the station in the security controller, the normal mode for a module's status LED is "on solid." Concurrently, the yellow RS-485 transmit LED will continuously flash, about 3 times per second. This reflects continuous polling of the expansion modules performed by the security controller.

If after applying power, the status LED goes out, and 12–15Vdc power is determined to be present, contact your Authorized Systems Distributor for technical assistance.

## UL REQUIREMENTS

This section provides requirements for a UL 294 Listed system. Failure to install the SEC-H-R2R/U, security controller, and other modules in accordance with these instructions voids the listing mark of Underwriters Laboratories, Inc.

- Mounting and Wiring
- Compatible Readers
- Battery-backed Power Supplies

### Mounting and Wiring

1. The SEC-H-R2R/U module must be mounted in a WEBS-AX Security Enclosure.
2. Enclosures must be mounted inside the secured area.
3. Grounding must be in accordance with Article 250 of the National Electrical Code.
4. Digital input DI1 of at least one item (security controller, any expansion module) in any enclosure must be wired to the enclosure's door tamper switch. See Fig. 9, page 15. If multiple WEBS-AX Security Enclosures are used in the system, each door tamper switch must also be wired to DI1 of *one* of its contained modules.
5. Only UL listed, 12V Wiegand-type readers can be used with the system.
6. Exit request input circuits and initiating devices must be contained within the secured area. Exit device circuits must be connected to UL listed switches or exit devices.
7. Door strike power must be provided from a UL listed burglar alarm system power supply. When required in accordance with NFPA 101, if the door strike circuit is arranged as fail secure (door remains locked upon loss of power), UL listed emergency panic hardware must be provided to allow exit from the secured area. A failsafe configuration results in the door strike circuit unlocking in case of a power loss.

### Compatible Readers

Compatible Readers (Reader Input rated 10.5–14 Vdc) are:

- HID — Models 5355, **5365**, 5375, **5395**, **5455**, **6005**, **6100**, **6120**, 6125, 6130
- GE Security — Model **T-200**

Only readers shown **bolded** above are also approved for use with the UL listed Battery-backed Power Supplies listed below. This includes HID models 5365, 5395, 5455, 6005, 6100, 6120, and GE Security model T-200 (Reader Input rated 8.1–14 Vdc).

### Battery-backed Power Supplies

The following battery-backed power supplies are approved for powering SEC-H-R2R/U and SEC-H-RIO/U modules:

**NOTE:** Configure power supply for 12Vdc output operation. Also see previous Compatible Readers section.

Honeywell <a href="http://www.honeywellpower.com/access.html">http://www.honeywellpower.com/access.html</a>	
Model	Output
HP300ULX	12/24Vdc 2.5A
HP400ULX	12/24Vdc 4.0A
HP600ULX/U	12/24Vdc 6.0A
HP300ULPD4CB/U	12/24Vdc 2.5A with Distribution PCB
HP400ULPD4CB/U	12/24Vdc 4.0A with Distribution PCB
HP600ULPD16CB/U	12/24Vdc 6.0A with Distribution PCB

AlarmSaf <a href="http://alarmsaf.com/">http://alarmsaf.com/</a>	
Model	Output
CPS-200C-7-UL/CSA	12/24Vdc 2.5A
CPS-400C-UL/CSA	12/24Vdc 4.0A
CPS-600C-UL/CSA	12/24Vdc 6.0A
CPS-800C-UL/CSA	12/24Vdc 8.0A

## NEW REPLACEMENT UNITS

To replace a faulty unit, order and install a *new* SEC-H-R2R/U module—please note that WEBS-AX Security series products do *not* have special "field replacement units," or FRUs, with separate part numbers.

If the faulty SEC-H-R2R/U is *still in warranty*, you can receive credit by returning it to Tridium. Be sure to contact Tridium for a return authorization (RA) number before shipping an item for return credit. See *Returning a Defective Unit*, page 22, for more details.

**NOTE:** Before ordering a new SEC-H-R2R/U module, it is strongly recommended that you contact your normal technical support resource to eliminate the possibility of a software issue or mis-configuration problem.

## REPLACING AN SEC-H-R2R/U MODULE



### CAUTION

Before handling circuit boards, discharge any accumulated static by touching a nearby earth grounding point. For details, see *Static Discharge Precautions*, page 3.

To replace the SEC-H-R2R/U expansion module in the field, proceed as follows:

1. Remove primary power to the module assembly with the SEC-H-R2R/U to be replaced. In some cases, this simply means removing the 6-position end connector. In the case of an SEC-H-R2R/U module mounted in-line with an enclosure power supply, de-energize the AC circuit powering the power supply.
2. Remove power to loads switched through the SEC-H-R2R/U relay outputs, such as door strikes.

**NOTE:** If adjacent modules are installed in the same module assembly, and loads are switched through onboard relays on them, turn the devices off or disconnect power to them also.

3. Note positions of all security I/O cables going to the SEC-H-R2R/U module, as well as all adjacent modules (if they must be moved). If necessary, label connectors and modules to avoid mis-connection later, after the SEC-H-R2R/U module is replaced.
4. Unplug all connectors from the SEC-H-R2R/U module, including all I/O connectors and earth ground wire.

**NOTE:** Removal of the larger screw terminal connectors from the circuit board pins may require gentle prying between the connector and the circuit board. When removing, grasp the connector firmly at both ends, and pull out from the circuit board. See *About Screw Terminal Connectors*, page 6.

5. If the SEC-H-R2R/U module is installed on a DIN rail by itself, or at the *right end* of an assembly, you can remove the 2 tab mounting screws that secure it, and then *slide* it away from the rest of the assembly. Then you can remove the SEC-H-R2R/U module from the DIN rail (see Fig. 1, page 5), leaving the mounting and wiring of other modules untouched.  
In this case, after removing the SEC-H-R2R/U module from the DIN rail, skip ahead to 7.
6. If the SEC-H-R2R/U module was installed on DIN rail to the *left* of other modules, you will need to remove the 2 tab mounting screws on each of the modules to its right, starting at the far right side. Slide each module away from the SEC-H-R2R/U module—enough to slide the SEC-H-R2R/U module away to free both end connectors. Be careful not to disturb wiring to other modules.  
In this case, now remove the SEC-H-R2R/U module from the DIN rail (see Fig. 1, page 5).
7. Mount the replacement SEC-H-R2R/U module as it was previously, using the same DIN rail location. See Fig. 1, page 5 for DIN rail mounting details.
8. Reconnect together with any other modules, being careful to position as before, using the same DIN rail location. Re-secure each module with screws in its 2 mounting tabs, as originally done.
9. Reconnect the Grounding wire to the grounding connector lug.
10. Reinstall the other security I/O screw terminal connectors onto the appropriate circuit board pins, including the Reader Inputs, Supervised Inputs, Relay Outputs, and Digital Inputs.
11. Restore power to loads switched through relay outputs, turn the devices back on, or reconnect power to them.
12. Restore primary power to the assembly with the SEC-H-R2R/U module. The “STATUS” LED on the SEC-H-R2R/U module should be blinking (see *Check the Status LEDs*, page 20).
13. For software re-configuration details, see the *WEBS-AX Enterprise User’s Guide*.

## Returning a Defective Unit

**NOTE:** If the defective unit is under warranty, please follow return instructions provided in this section. If the unit is *out of warranty*, please discard it.

**Do not return an out-of-warranty SEC-H-R2R/U module to Tridium.**

**There is no “return for repair-and-return” service available for any of the WEBS-AX Security products.**

For proper credit on an in-warranty unit, ship the defective unit to Tridium within 30 days.

Prior to returning the unit, contact one of the following Tridium offices to obtain a return authorization (RA) number and other instructions. Please provide:

- Product model
- Serial number
- Nature of the defect

## United States

**Phone:** 804-254-7086, ext. 11

**Return to:**

Tridium, Inc.  
2256 Dabney Road, Suite C  
Richmond, VA 23230  
Attn: Return Department RA# \_\_\_\_\_

**Email for RMA:**  
[rma@tridium.com](mailto:rma@tridium.com)

## Asia/Pacific

**Phone:** +65 6887 5154

**Fax:** +65 6887 5342  
**Mobile:** +65 9665 6024

**Address:**

Tridium Asia Pacific Pte Ltd  
17 Changi Business Park Central 1  
Honeywell Building  
Singapore 486073  
Attn: Mr Lim Hoon Chiat, Engineering Manager RA# \_\_\_\_\_

**Email for technical support:**  
[hclim@WEBs-AX.com](mailto:hclim@WEBs-AX.com)

**Sales:** (Australia): **Phone:** +61 4 1264 4234 **Fax:** +61 7 5597 2334

(Japan): **Phone:** +81 044 829 1750

## CERTIFICATIONS

The SEC-H-R2R/U module meets the certifications listed below. For further details, please see the corresponding sections in the appropriate *Security Controller (model) Installation Instructions*.

**Installation** : The control units and accessories are intended to be installed in accordance with the following:

1. The National Electrical Code, ANSI/NFPA 70.
2. Canadian Electrical Code, Part I.
3. Local Authority having Jurisdiction.

## Underwriters Laboratories, Inc (UL) / Canadian Standards Association (CSA)

When installed in accordance with UL requirements, this equipment meets the following UL listing:

- UL 294 Access Control System Units
- CSA No. C22.2 No. 205 Signal Equipment

See UL Requirements, page 21 for more details.

## Federal Communications Commission (FCC)

Class A computing device pursuant to Subpart J of Part 15 of FCC Rules.

## Canadian Department of Communications (DOC)

Class A digital apparatus meeting requirements of the Canadian Interference-Causing Equipment Regulations.

### Automation and Control Solutions

Honeywell International Inc.

1985 Douglas Drive North

Golden Valley, MN 55422

customer.honeywell.com

# Honeywell