

## CT3300 Programmable Thermostat

### INSTALLATION AND PROGRAMMING INSTRUCTIONS

**Welcome** to the world of comfort and energy savings with your new Honeywell Programmable Thermostat. Your new thermostat will automatically control the temperature in your home, keeping you comfortable while saving energy.

Weekday/Weekend (5-day/2-day)  
Programmable Heat and/or Cool  
Low Voltage (20 to 30 Vac)  
Thermostat and Mounting Plate  
Model CT3300



### Table of Contents

Installation .....	2
Programming .....	11
Operation .....	17
Frequently Asked Questions .....	22
Customer Assistance .....	23
Limited Warranty .....	24





# MERCURY NOTICE

If you are removing an old thermostat that contains mercury in a sealed tube (Fig. 1), **do not** place the old thermostat in the trash. Contact your local waste management authority for instructions regarding recycling and the proper disposal of the old thermostat.

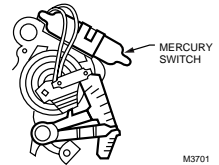

M3701

Fig. 1.

## INSTALLATION

### Verify You Have Correct Thermostat

Make sure that the CT3300 is the correct thermostat for your heating/cooling system. Read the compatibility chart below to determine which system you have. If your system is not compatible with the CT3300, the table recommends an alternate Honeywell model. If you are unsure what type of thermostat is right for your system, visit us on the Web at [www.honeywell.com/yourhome](http://www.honeywell.com/yourhome) or call Honeywell Customer Care at 1-800-468-1502.

Heating/Cooling System	Compatible with CT3300?	Alternate Model
<b>Conventional</b> Single stage systems that include warm air furnaces and hot water.	Yes	
<b>Electric Baseboard</b> Electric-powered heating strips located just above the floor, usually 120 to 240 volts.	No	CT1950 for 240 volts

Heating/Cooling System	Compatible with CT3300?	Alternate Model
<b>Steam</b> A steam boiler with radiator heat.	No	CT3600
<b>Heat Pump</b> Heating and cooling are produced from the same outdoor unit (compressor) with no auxiliary or backup heat.	No	CT3600
<b>Multistage Heat Pump</b> Heating and cooling are produced from the same outdoor unit (compressor) with auxiliary or backup heat.	No	CT3611
<b>Multistage Conventional</b> A heating or cooling system with more than one stage.	No	See your contractor

## Step 1. Prepare for Installation

- Carefully unpack your new thermostat. Save your receipt and make sure you have the following parts:
  - Thermostat and mounting plate.
  - Labels.
  - Screws and anchors.
  - Installation and Programming Instructions.
- Gather the needed tools and supplies listed below.

Required Tools and Supplies	Optional Tools
<ul style="list-style-type: none"> <li>Two AA alkaline batteries. Honeywell recommends Energizer® batteries.</li> <li>Screwdriver.</li> <li>Hand or power drill with 3/16-inch or 7/32-inch drill bit.</li> <li>Pencil.</li> </ul>	<ul style="list-style-type: none"> <li>Wire cutter/stripper or sharp knife.</li> <li>Level.</li> <li>Electrical tape.</li> </ul>

- Make sure that your heating and cooling systems are working correctly. If there is a problem with either system, call a heating/air conditioning contractor—the problem may persist after you install the new thermostat.

### **IMPORTANT:**

*To avoid damaging the compressor in the air conditioner, do not operate the cooling system when the temperature outdoors is below 50°F (10°C).*

## Step 2. Remove Old Thermostat

Fig. 2.

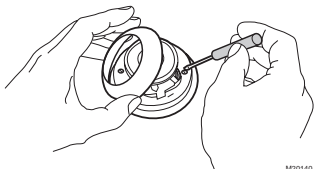

Fig. 3.

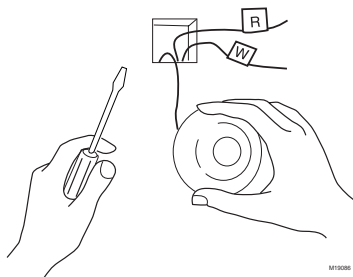
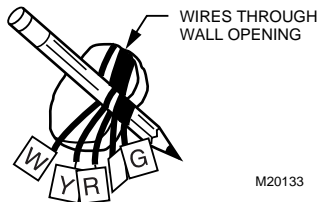

Fig. 4.



- a. **Turn off power** to the heating/cooling system, either at the furnace or at the fuse/circuit breaker panel.
- b. Remove the cover of your old thermostat (Fig. 2).
- c. Unscrew and remove the old thermostat's mounting plate from the wall, but **do not disconnect the wires**.
- d. Inspect the old thermostat wiring. **If wiring meets any of the following conditions, see special wiring instructions section after Step 7.**
  - The old thermostat is a clock thermostat with wires attached to the C or C1 terminals.
  - The old thermostat has six or more wires, excluding wires attached to C or C1 terminals.
  - The old thermostat has three wires.
  - There are five wires **connected** to the old thermostat.
  - There are extra wires that are **not** connected to the old thermostat.
- e. Using enclosed labels, mark wires with letter of terminal it is attached to on the **old thermostat** (Fig. 3). Do not label using colors. If labels do not match letters on old thermostat terminals, see wiring cross reference table in Special Wiring Instructions section.
- f. Disconnect the wires from the old thermostat and wrap the wires around a pencil to keep them from falling back into the wall.

**NOTE:** Remember, if your old thermostat contains mercury, you must recycle it. See Mercury Notice for more recycling information.

### ✓ Check your progress

Your wall should now look like Fig. 4.

## Step 3. Install Mounting Plate

Fig. 5.

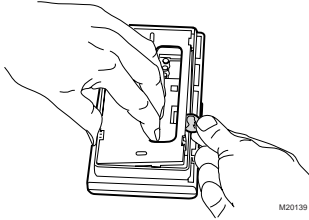

Fig. 6.

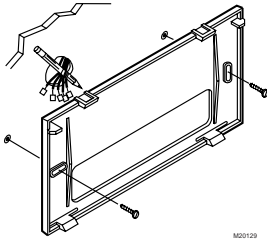
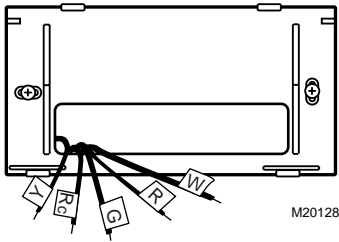

Fig. 7.



- a. Separate the mounting plate from the thermostat using a coin, as shown in Fig 5.
- b. Position the mounting plate on the wall. Be sure the mounting plate is flush against the wall and none of the wires are trapped behind it.
- c. Level the mounting plate and use a pencil to mark the center of the mounting plate screw holes.
- d. Remove the mounting plate and drill holes at the locations marked.
  - For drywall, drill two 3/16-inch holes.
  - For plaster or wood, drill two 7/32-inch holes.
- e. If installing in drywall, gently tap the anchors (provided) into the drilled holes until they are flush with the wall.
- f. Reposition the mounting plate over the holes, pull the wires through the wiring opening, and loosely insert the mounting screws into each of the drilled holes or anchors (Fig. 6).
- g. Make sure the mounting plate is level and tighten the mounting screws.

### ✓ Check your progress

The mounting plate is now mounted on the wall and should look like Fig. 7.

## Step 4. Set Thermostat for Your Type of Heating System

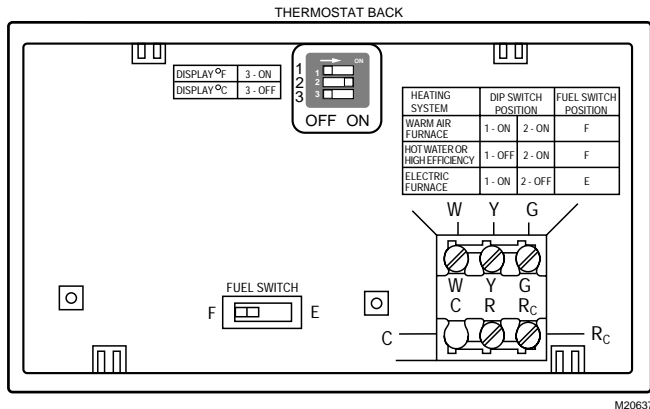

**Fig. 8.**

### **IMPORTANT:**

*Setting your thermostat correctly for your type of heating system allows it to maintain accurate temperature control, minimize swings in the temperature of the room, and efficiently run the fan.*

a. Use the FUEL SWITCH on the back of the thermostat to set your new thermostat for the type of fuel that your heating system uses: F—gas or oil, or E—electric.

NOTE: This setting enables correct fan operation.

b. Use DIP switches 1 and 2 on the back of the thermostat to set your new thermostat for your type of heating system. See the Heating System Table on the next page to find the correct settings.

NOTE: These DIP switches are factory-set for a warm air, gas, or oil heating system.

- c. The thermostat is set to display the temperature in degrees Fahrenheit (°F). If you want to display the temperature in degrees Celsius (°C), turn DIP Switch 3 to Off position.
- d. You can install the batteries and program your thermostat now, or you can wait until the thermostat is mounted on the wall. To install the batteries, see Step 7. To program the thermostat, see the Programming section.

# Heating System Table

Type of System	DIP Switches 1 and 2	Fuel Switch
Warm air, gas, or oil heating system with an efficiency rating under 90%. (The furnace efficiency rating should be on the furnace.)	Use factory setting 1—On; 2—On	F
High-efficiency furnace such as a 90% or greater AFUE (Average Fuel Utilization Efficiency) unit.	1—Off; 2—On	F
Hot water boiler	1—Off; 2—On	F
Electric furnace	1—On; 2—Off	E

## Step 5. Wire Thermostat Terminals

Fig. 9.

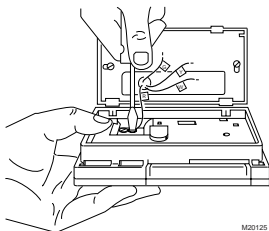

- Hold thermostat as shown in Fig. 9.
- Using the labels on the wires, match letter of your old thermostat wire with the corresponding terminal on the back of your new thermostat.

**NOTE:** If letters on old thermostat terminals do not match letters on new thermostat terminals, all old wires may not need connecting to new thermostat. See Special Wiring Instructions section.

Fig. 10.

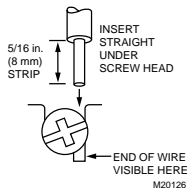

- Loosen terminal screws and slip each wire beneath its matching terminal (Fig 10).
- Securely tighten terminals.

## Step 6. Mount Thermostat

Fig. 11.

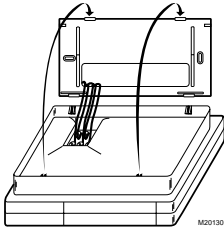
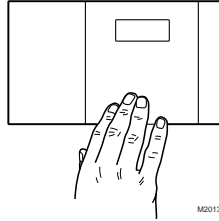

Fig. 12.



- e. Align the tabs at the **top** of the thermostat with the tabs at the **top** of the mounting plate (Fig. 11).
- f. Press the lower edge of the case to latch the bottom of the thermostat (Fig. 12)

## Step 7. Install the batteries

Fig. 13.

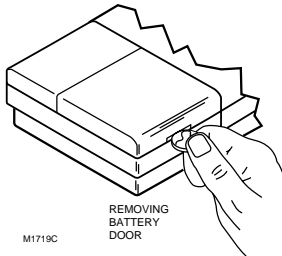

### **IMPORTANT:**

*Batteries must be installed for programming and operation of the thermostat and heating/cooling system. Honeywell recommends using Energizer® batteries.*

- a. Make sure that the System switch is set in the Off position.
- b. Using a coin, open the battery door as shown in Fig. 13.
- c. Install the batteries. Make sure that the positive and negative terminals are oriented correctly as marked inside the battery case.
- d. Replace the battery door.
- e. Remove the clear plastic label from the digital display.

Fig. 14.

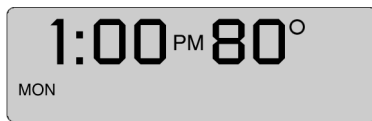

### **✓ Check your progress**

When the batteries are installed correctly, the digital display flashes all entries once, then begins to flash a default time and the current temperature (Fig. 14). The flashing continues until you begin to program the thermostat. You are now ready to program the thermostat. See Programming section.



# Special Wiring Instructions

## Clock thermostat with C or C1 terminals

A clock thermostat has one or two extra wires attached to C or C1 terminals for clock operation that are not used when installing your thermostat. They must be insulated from each other to avoid damaging your electrical circuit.

- Make sure that power to the heating/cooling system is **turned off**.
- Locate wires that are connected to clock terminals marked C or C1.
- As you disconnect the wires, do not allow these wires to touch.
- Wrap wires **separately**, using electrical tape to insulate the wires.
- Place wires to avoid interfering with new thermostat operation. They are not used with your 3300 Thermostat.
- Continue with the installation.

## Six or more wires

If old thermostat has six or more wires (excluding clock wires attached to C or C1 terminals), your heating/cooling system is a variation of a heat pump or multistage system. See thermostat compatibility table located before Step 1. Your 3300 Thermostat does not work with such systems and should be returned to the place of purchase.

## Three thermostat wires

If you have three wires for heating only and can operate the fan using Fan On switch, the 3300 Thermostat works with your system. Continue installation procedure. If you have three-wire heating-only system and cannot operate fan using Fan On switch, the 3300 Thermostat does **not** work with your system. Contact your heating contractor for installation.

## Wires that are not connected to old thermostat

For extra wires that do not connect to your old thermostat, do not label them or connect these wires. Tape them with electrical tape and place them to avoid interfering with operation of new thermostat. Continue installation procedure.

## Five wires connected to old thermostat

Your new thermostat has a factory-installed metal jumper between the R and Rc terminals (Fig. 15). Remove jumper before wiring R and Rc terminals.

Fig. 15.

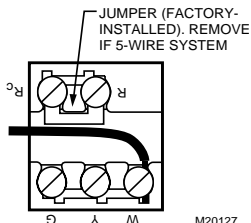

M20127

## Old thermostat terminals that do not match new thermostat terminals

Use the table below to wire the new thermostat.

Old Thermostat Terminal	Connect to New Thermostat Terminal	Description
R, RH, 4, V	R*	Power
Rc, R	Rc*	Power for cooling
W, W <sub>1</sub> , H	W	Heat
Y, Y <sub>1</sub> , M	Y	Cooling
G, F	G	Fan
O B	Do not continue installation	Changeover in cool (O terminal) or changeover in heat (B terminal). You have a single-stage heat pump or zoning system. Select an alternate thermostat model.
C, X, B	Do not connect	Transformer common.
W <sub>2</sub> , H <sub>2</sub> Y <sub>2</sub>	Do not continue installation.	Second stage heat (W <sub>2</sub> , H <sub>2</sub> ) or second stage cooling (Y <sub>2</sub> ). You have a multistage heating/cooling system. Select an alternate thermostat model.

\*Remove factory-installed jumper between R and Rc terminals in 5-wire systems.

# PROGRAMMING

## Faceplate Illustration and Description

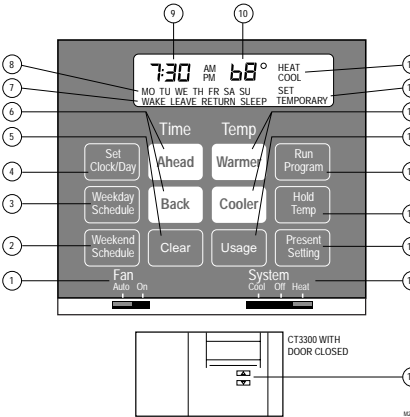
		Description	
<b>Fig. 16.</b>		1	Fan switch—Selects automatic or continuous fan operation.
		2	Weekend Schedule—Initiates programming of weekend heating or cooling schedule.
		3	Weekday Schedule—Initiates programming of weekday heating or cooling schedule.
		4	Set Clock/Day—Sets clock and day.
		5	Clear—Cancels displayed program and clears usage counter.
		6	Time Ahead and Back—Sets the time ahead and back.
		7	Program periods—Current program period(s) being programmed.
		8	Day—Current day(s) being programmed.
		9	Time—Current time or program time.
		10	Temperature—Room or programmed temperature.
		11	HEAT/COOL—Indicates if heating or cooling schedule is running or being programmed.
		12	TEMPORARY—Displays temporary override made to program.
		13	Temp Warmer and Cooler—Raises or lowers temperature.
		14	Usage—Displays how long heating/cooling system was running.
		15	Run Program—Returns thermostat to operating mode.
		16	Hold Temp—Holds a selected temperature.
		17	Present Setting—Displays temperature setting for current period.
		18	System switch—Selects Cool, Off, Heat.
		19	Arrow buttons—Allow you to temporarily change temperature without opening faceplate door.

## Step 1. Set Current Time and Day

- a. Press **Set Clock/Day** once.  
The time is displayed (Fig. 17).
- b. Press and hold **Ahead** or **Back** until the current time is displayed.
- c. Press **Set Clock/Day** again.  
The day is displayed (Fig. 18).
- d. Press and hold **Ahead** or **Back** until the current day is displayed.
- e. Press **Run Program** once.  
The current time and day and the current temperature are displayed (Fig. 19).

Fig. 17.

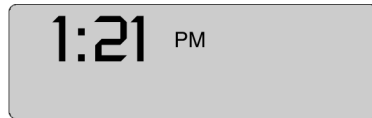
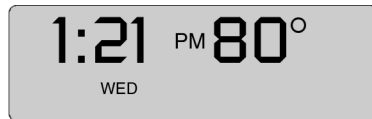

Fig. 18.



Fig. 19.



## Step 2. Learn About Programming Features

Your CT3300 Thermostat allows you to program schedules for both a heating season and a cooling season.

- During the heating season, you will want to set the normal room temperature higher and the energy-saving temperature lower.
- The reverse is true during the cooling season—the normal room temperature will be lower and the energy-saving temperature higher.



For each season, you can set up to four program periods for the weekdays (Monday–Friday), and up to two program periods for the weekends (Saturday and Sunday). The program periods are defined in the following table.

Program Period	Description	When Available
WAKE	The time when you get up and get ready to leave your home. You can set the system at a comfortable temperature for this period.	Weekdays and weekend
LEAVE	The time when you are regularly away from home. You can set up an energy-saving temperature for this period.	Weekdays only
RETURN	The time between returning home and going to bed. You can set the system at a comfortable temperature for this period.	Weekdays only
SLEEP	The time when you are sleeping. You can set up an energy-saving temperature for this period.	Weekdays and weekend

## Programming Tips

- You do not need to program times and temperatures for all program periods. If you decide not to program your thermostat, it automatically controls heating at 68°F (20°C), and cooling at 78°F (26°C), 24 hours a day.

If you decide not to program weekend schedules, the temperature that is programmed for the weekday SLEEP schedule remains in effect until the next program period, which begins on Monday morning.

- The temperatures cannot be set any higher than 88°F (31°C) or any lower than 45°F (7°C).
- When pressing the buttons, use the ball of your finger or a soft pencil eraser. Using sharp fingernails or pencil points can damage the keypad.
- If you make an error at any time during programming, press . Then press  or .

### Step 3. Program Heating Schedule

a. Write in the times and temperatures that you want to program for your heating schedule.

Heating Schedule	Program Period	WAKE	LEAVE	RETURN	SLEEP
Suggested Settings	Time	6:00 AM	8:00 AM	6:00 PM	10:00 PM
	Temp	70°F (21°C)	62°F (16.5°C)	70°F (21°C)	62°F (16.5°C)
Weekday (Mon–Fri)	Time				
	Temp				
Weekend (Sat–Sun)	Time				
	Temp				

b. Set the System switch to HEAT.

c. Press **Weekday Schedule** once.

A blank schedule is displayed (Fig. 20).

Fig. 20.

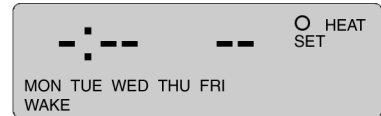

d. Set the Monday–Friday WAKE time by pressing **Ahead** or

**Back** until the desired time is displayed (Fig. 21).

e. Set the Monday–Friday WAKE temperature by pressing

**Warmer** or **Cooler** until desired temperature is displayed.

Fig. 21.

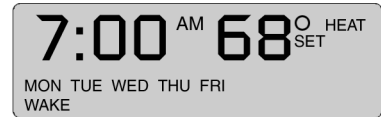

- f. Press **Weekday Schedule** to display a blank schedule for the next program period (Fig. 22) and repeat steps d. through f. for each weekday program period.

Fig. 22.

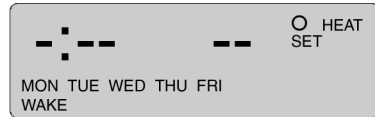

- g. Press **Weekend Schedule** until the weekend schedule is displayed (Fig. 23).
- h. Set the Saturday and Sunday WAKE time by pressing **Ahead** or **Back** until the desired time is displayed.
- i. Set the Saturday and Sunday WAKE temperature by pressing **Warmer** or **Cooler** until desired temperature displays (Fig. 24).

Fig. 23.



- j. Press **Weekend Schedule** again to display blank schedule for the SLEEP program period and repeat steps h. through j. to set the program.
- k. Press **Run Program** to start the program.

Fig. 24.

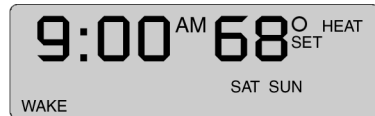

## Step 4. Program Cooling Schedule

- a. Write in the times and temperatures you want to program for your cooling schedule.

Cooling Schedule	Program Period	WAKE	LEAVE	RETURN	SLEEP
Suggested Settings	Time	6:00 AM	8:00 AM	6:00 PM	10:00 PM
	Temp	78°F (25.5°C)	85°F (29.5°C)	78°F (25.5°C)	82°F (28°C)
Weekday (Mon–Fri)	Time				
	Temp				
Weekend (Sat–Sun)	Time				
	Temp				

- b. Set the System switch to Cool.  
 c. Repeat steps 3c. through 3k. to program the weekday and weekend cooling schedule.

## Step 5. Check System

### Verify that your heating system works

- a. Set the System switch to Heat, and the Fan switch to Auto. **Fig. 25.**
- b. Press **Warmer** until the setting is 10°F (6°C) above room temperature (Fig. 25). Your heating system should start and the fan should run after a short delay.
- c. Press **Cooler** until the setting is 10°F (6°C) below room temperature. Your heating system should shut off.

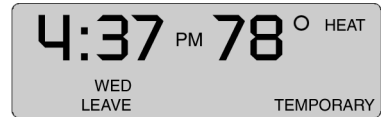

### Verify that your cooling system works

#### **IMPORTANT:**

*To avoid damaging the compressor in the air conditioner, do not operate the cooling system when the temperature outdoors is below 50°F (10°C).*



d. Set the System switch to Cool, and the Fan switch to Auto. **Fig. 26.**

e. Press **Cooler** until the setting is 10°F (6°C) below room temperature (Fig. 26). Your cooling system and fan should start.

**NOTE:** When cooling setting is changed, thermostat can delay up to five minutes before turning on air conditioner. This delay protects the compressor.

f. Press **Warmer** until setting is 10°F (6°C) above room temperature. Your cooling system and fan should stop.

g. Set the System switch to Off and the Fan switch to Auto. The cooling system and fan should be off.

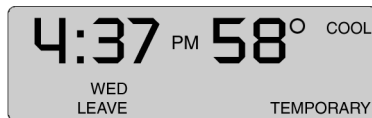

## OPERATION

### Change Clock for Daylight/Standard Time

a. Press **Set Clock/Day** once. The time is displayed.

b. Press and hold **Ahead** or **Back** until the correct time is displayed.

c. Press **Run Program** once. The current time and day and current temperature display.

## Set Fan and System Switches

The switches on the bottom of the thermostat faceplate control the operation of your fan and the heating and cooling system. Set the Fan switch first and then set the System switch.

Switch	Setting	Result
Fan	Auto	A single-speed fan turns on automatically with the air conditioner or furnace. A two-speed fan usually runs on high with the air conditioner and on low with the furnace. Auto is the normal setting for most homes.
	On	The fan runs continuously. Use this setting for improved air circulation during special occasions or for more efficient air cleaning.  NOTE: In a heat-only system, the fan runs continuously only if the fan wire has been connected to the G terminal on the back of the thermostat.
System	Cool	The thermostat controls your air conditioning system.
	Off	Both the heating and air conditioning systems are off.
	Heat	The thermostat controls your heating system.

## Replace Batteries

As the batteries run low, your thermostat shows the following in the digital display:

If you see:	Batteries are:	You should:
Flashing "bAt Lo"	Low	Replace the batteries as soon as possible, within the month.
Blank display	Dead	Replace the batteries immediately. Your heating/cooling system is not operating.

- Make sure that the System switch is set to the Off position.
- Open the battery door.
- Press on the left side of the batteries to remove them.

NOTE: If new batteries are inserted within 20 to 30 seconds of removing old ones, reprogramming is not needed. If display is blank, batteries are dead or incorrectly installed and reprogramming is needed.

- d. Install new batteries. Make sure that positive and negative terminals are oriented as marked inside battery case.
- e. Close the battery door and set the System switch to Heat or Cool.

NOTE: If “bAt Lo” continues to display after replacing the batteries, set System switch to Off, insert batteries backward, wait for five to ten seconds, and return batteries to correct orientation. Then reprogram.

**IMPORTANT:**

*Replace batteries once a year to prevent heating/cooling system from shutting down due to lack of battery power in thermostat. If leaving home for longer than a month, change batteries before leaving.*

## Override program settings

NOTE: Make sure the System switch is set to either Heat or Cool before making any changes to the schedule.

### Change the temperature temporarily

Press  or  until desired temperature displays.

The TEMPORARY indicator displays, indicating that the change is temporary.

NOTE: A temporary change to temperature lasts for current program period only. Heating/cooling schedule you programmed resumes when next scheduled program period is reached. To cancel temporary change before

next scheduled program period, press .

Fig. 27.



## Hold a temperature indefinitely

Use the Hold Temp feature when you want to maintain a constant temperature indefinitely, such as when you go on vacation.

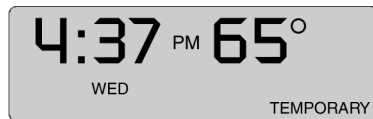
- Press **Hold Temp**. "HLd" is displayed (Fig. 28).
- Press **Warmer** or **Cooler** until the desired temperature is displayed.

The display shows the SET temperature for a few seconds and then resumes reading the current room temperature.

NOTE: To cancel the hold, press **Run Program**.

## Check the current programmed temperature

Press **Present Setting** to display temperature programmed for current program period. The SET indicator displays briefly along with the programmed temperature (Fig. 29). The display then returns to the room temperature.

## Check programs

Press **Weekday Schedule** repeatedly to display the times and temperatures that you programmed for the weekdays (Monday through Friday).

Press **Weekend Schedule** repeatedly to display the programmed times and temperatures for the weekend (Saturday and Sunday).

- Press **Run Program** to resume the program

Fig. 28.



Fig. 29.

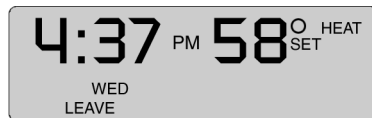

## Cancel a program

- Press **Weekday Schedule** or **Weekend Schedule** until the desired program is displayed (Fig 30).
- Press **Clear** .  
A blank program schedule is displayed and the program is canceled (Fig. 31).

## Check how long heat/air conditioning has been running

- Since 12:00 AM today, press **Usage** once. (Fig. 32).
- Since 12:00 AM yesterday, press **Usage** twice (Fig. 33).
- Since installation or since last time you reset cumulative usage counter, press **Usage** three times.

## Reset cumulative usage counter to zero

- Press **Usage** three times to display cumulative reading.
- Press **Clear** to set counter to zero (Fig 34).
- Press **Run Program** .

Fig. 30.

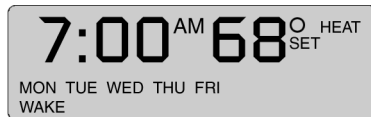

Fig. 31.

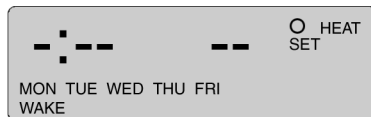

Fig. 32.



Fig. 33.



Fig. 34.



## Change a program permanently

Follow steps for programming heating schedule or programming cooling schedule.

## FREQUENTLY ASKED QUESTIONS

If...	Then...
Display does not come on	<ul style="list-style-type: none"><li>• Make sure the batteries are fresh and installed correctly.</li><li>• Set System switch to Off. Remove batteries and insert backward for five to ten seconds to reset thermostat. Replace batteries correctly; display should come on.</li></ul>
Temperature display does not go lower than 45°F (7°C) or higher than 88°F (31°C) during programming.	<ul style="list-style-type: none"><li>• Temperature limit setting is reached; range is 45°F to 88°F (7°C to 31°C).</li></ul>
Display shows flashing “bAt Lo.”	<ul style="list-style-type: none"><li>• The batteries are low; replace them as soon as possible.</li><li>• If “bAt Lo” continues to display after replacing batteries, set System switch to OFF and insert batteries backward for five to ten seconds. Replace batteries correctly; display should come on.</li></ul>
Temperature change occurs at wrong times	<ul style="list-style-type: none"><li>• Check program times for period in question. Be sure AM and PM indications are correct. Make sure current day and time are correct. Reprogram if necessary.</li></ul>
Heating does not come on	<ul style="list-style-type: none"><li>• Check that the System switch is set to Heat.</li><li>• Check the system fuse or circuit breaker and replace or reset if necessary.</li><li>• Check for correct wiring and good connections.</li><li>• If display is blank or displays “bAt Lo,” install fresh batteries.</li><li>• Allow time for the furnace to heat up and the fan to come on before checking for heat at the register.</li><li>• If temperature setting is higher than current room temperature and System On arrow is displayed, thermostat is operating correctly. Contact heating contractor for assistance.</li></ul>

If...	Then...
Cooling does not come on	<ul style="list-style-type: none"> <li>• Check that the System switch is set to Cool.</li> <li>• Check the system fuse or circuit breaker and replace or reset if necessary.</li> <li>• Check for correct wiring and good connections.</li> <li>• If display is blank or says "bAt Lo," install fresh batteries.</li> <li>• The thermostat has a built-in time delay on cooling. Allow 5-10 minutes after changing setting before air conditioner starts.</li> <li>• If temperature setting is lower than room temperature and System On arrow is displayed, thermostat is operating correctly. Contact ac contractor.</li> </ul>
House is too warm or too cool	<ul style="list-style-type: none"> <li>• Press  to check the current temperature setting.</li> <li>• If desired, change the temperature setting.</li> </ul>
Furnace cycles too often or system cycle length is too short or too long	<ul style="list-style-type: none"> <li>• Adjust the screws on the back of the thermostat.</li> </ul>
Thermostat current setting does not match the display temperature to within plus or minus 1°	<ul style="list-style-type: none"> <li>• Plug the wiring hole in the wall behind the mounting plate with insulation to prevent drafts that might adversely affect thermostat operation.</li> <li>• Be aware that it is normal for the current setting and the displayed room temperature to differ on occasion.</li> <li>• During recovery from setback or setup, setting and displayed room temperatures can differ for up to 30 minutes after recovery period.</li> </ul>

## CUSTOMER ASSISTANCE

Visit us on the Web at [www.honeywell.com/yourhome](http://www.honeywell.com/yourhome) or call Honeywell Customer Care at 1-800-468-1502.

Before you call, please have the following information available:

- Thermostat model number and serial code (located under the battery cover).
- Type of heating/cooling system (hot water, warm air, oil, gas, etc.).
- Number of wires connected to the thermostat.

**NOTICE:** This equipment is a Class B digital apparatus, that complies with Canadian Radio Interference Regulations, CRC c.1374.

# LIMITED WARRANTY

Honeywell warrants this product, excluding battery, to be free from defects in workmanship or materials, under normal use and service, for a period of one (1) year from the date of purchase by the consumer. If, at any time during the warranty period, the product is defective or malfunctions, Honeywell shall repair or replace it (at Honeywell's option) within a reasonable period of time. If the product is defective,

(i) return it, with a bill of sale or other dated proof of purchase, to the retailer from which you purchased it, or  
(ii) package it carefully, along with proof of purchase (including date of purchase) and a short description of the malfunction, and mail it, postage prepaid, to the following address:

Honeywell Inc. USA  
Dock 4 — MN10-3860  
1885 Douglas Drive North  
Golden Valley, MN 55422-3992

Honeywell Canada:  
Honeywell Limited/Honeywell Limitée  
35 Dynamic Drive  
Scarborough, Ontario M1V 4Z9

This warranty does not cover removal or reinstallation costs. This warranty shall not apply if it is shown by Honeywell that the defect or malfunction was caused by damage which occurred while the product was in the possession of a consumer.

Honeywell's sole responsibility shall be to repair or replace the product within the terms stated above. HONEYWELL SHALL NOT BE LIABLE FOR ANY LOSS OR DAMAGE OF ANY KIND, INCLUDING ANY INCIDENTAL OR CONSEQUENTIAL DAMAGES RESULTING, DIRECTLY OR INDIRECTLY, FROM ANY BREACH OF ANY WARRANTY, EXPRESS OR IMPLIED, OR ANY OTHER FAILURE OF THIS PRODUCT. Some states do not allow the exclusion or limitation of incidental or consequential damages, so this limitation may not apply to you.

THIS WARRANTY IS THE ONLY EXPRESS WARRANTY HONEYWELL MAKES ON THIS PRODUCT. THE DURATION OF ANY IMPLIED WARRANTIES, INCLUDING THE WARRANTIES OF MERCHANTABILITY AND FITNESS FOR A PARTICULAR PURPOSE, IS HEREBY LIMITED TO THE ONE YEAR DURATION OF THIS WARRANTY. Some states do not allow limitations on how long an implied warranty lasts, so the above limitation may not apply to you.

This warranty gives you specific legal rights, and you may have other rights which vary from state to state.

If you have any questions concerning this warranty, please write Honeywell Customer Relations Center, 1985 Douglas Dr. N., Golden Valley, MN 55422-3992, or call 1-800-468-1502. In Canada, write Retail Products ON30 Honeywell Limited/Honeywell Limitée, 35 Dynamic Drive, Scarborough, Ontario M1V 4Z9.

## Honeywell

### Automation and Control Solutions

Honeywell International Inc.	Honeywell Limited-Honeywell Limitée
1985 Douglas Drive North	35 Dynamic Drive
Golden Valley, MN 55422	Scarborough, Ontario
	M1V 4Z9