

SmartVFD Frame 8 Wiring Diagrams and Dimensional Drawings

SPECIFICATION DATA

SmartVFD Frame Size 8

460 Vac: 100-150 HP

208/230 Vac: 50-75 HP

CONTENTS

SmartVFD Frame 8 Wiring Diagrams	2
Frame 8, Fused Disconnect Wiring Diagram	2
Frame 8, 2 Contactor Wiring Diagram	3
Frame 8, 3 Contactor Wiring Diagram	4
Frame 8, 3 Contactor Auto-bypass Wiring Diagram	5
SmartVFD Frame 8 Dimensional Diagrams	6
Frame 8 NEMA 1: Disconnect Only and 2 Contactor Dimensional Drawing	6
Frame 8 NEMA1: 3 Contactor & 3 Contactor with Auto-Bypass Dimensional Drawing	7
Frame 8: NEMA3R, Disconnect only, 2 Contactor, 3 Contactor and 3 Contactor with Auto-Bypass Drawing	8



SMARTVFD FRAME 8 WIRING DIAGRAMS AND DIMENSIONAL DRAWINGS

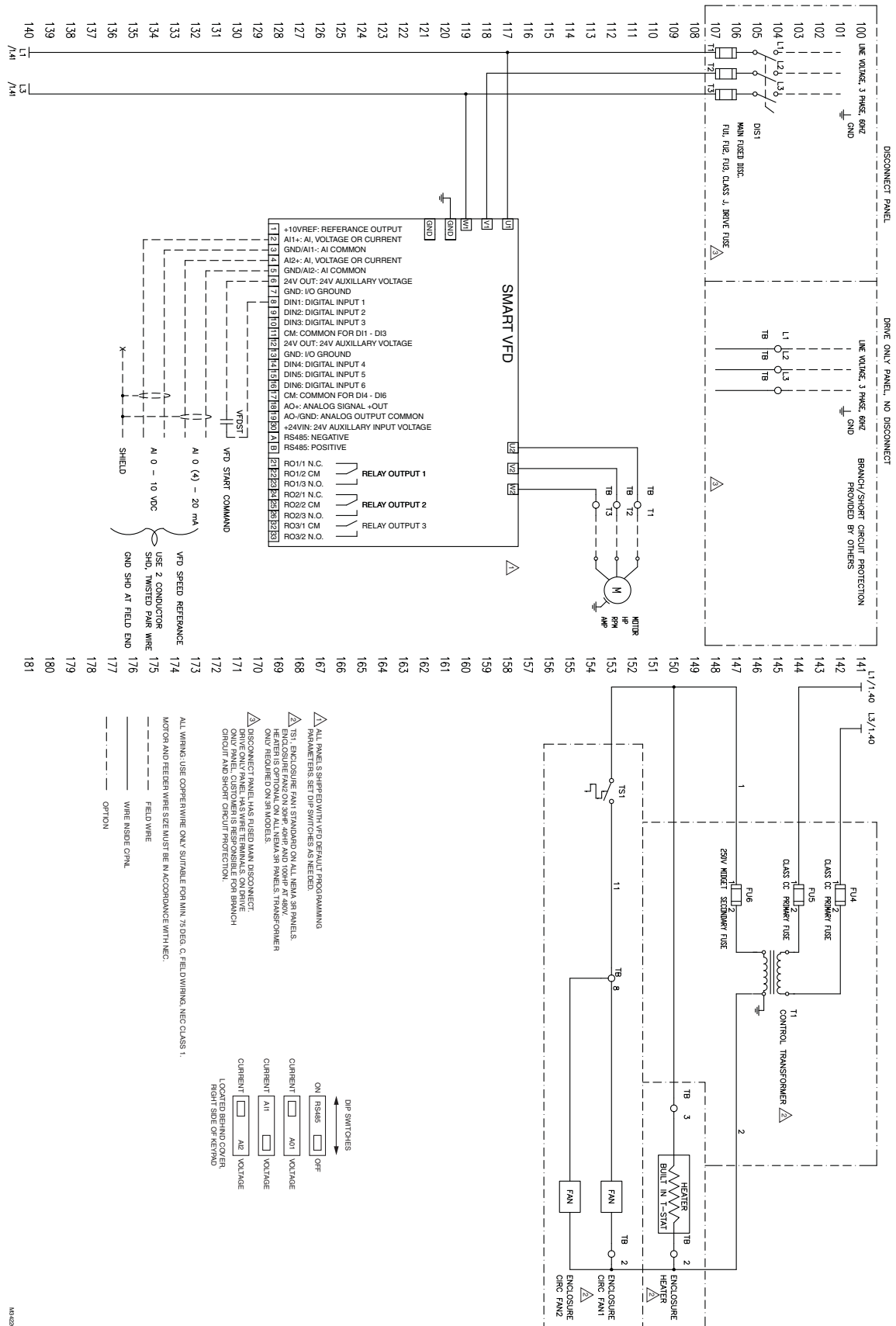

Fig. 1. Frame 8, Fused Disconnect Wiring Diagram

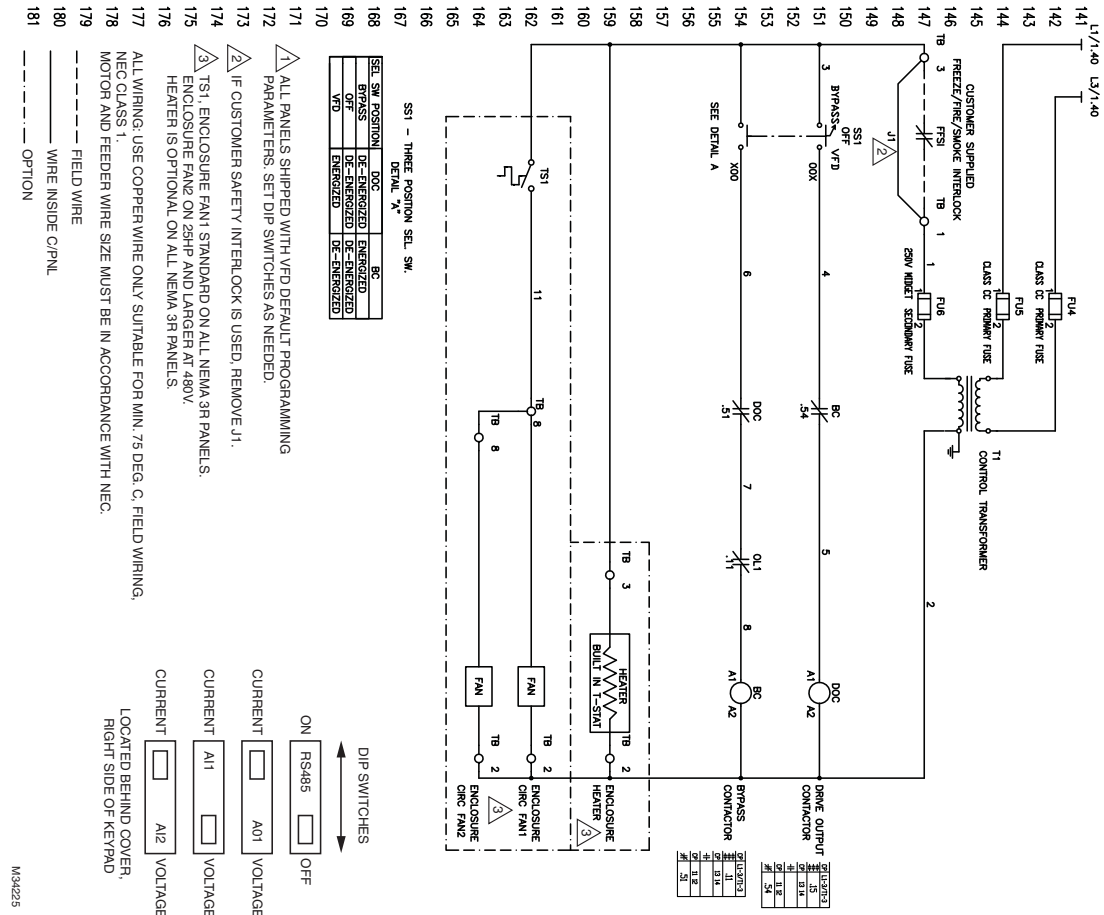
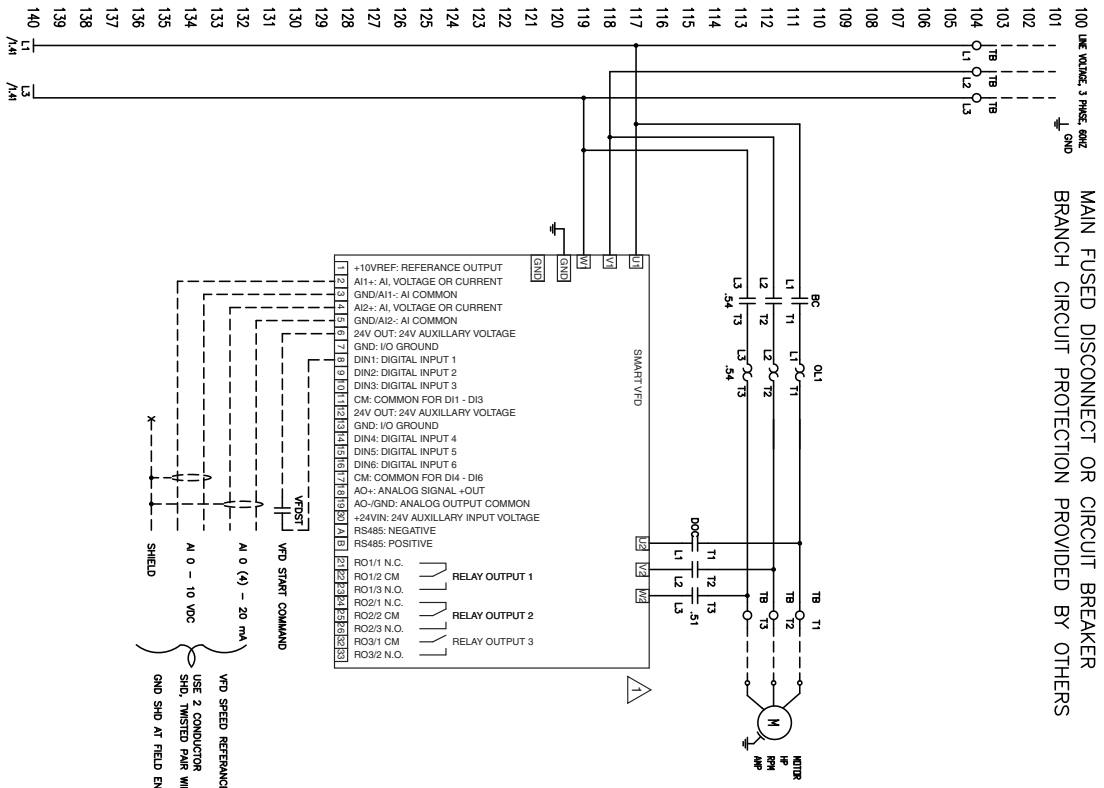

Fig. 2. Frame 8, 2 Contactor Wiring Diagram

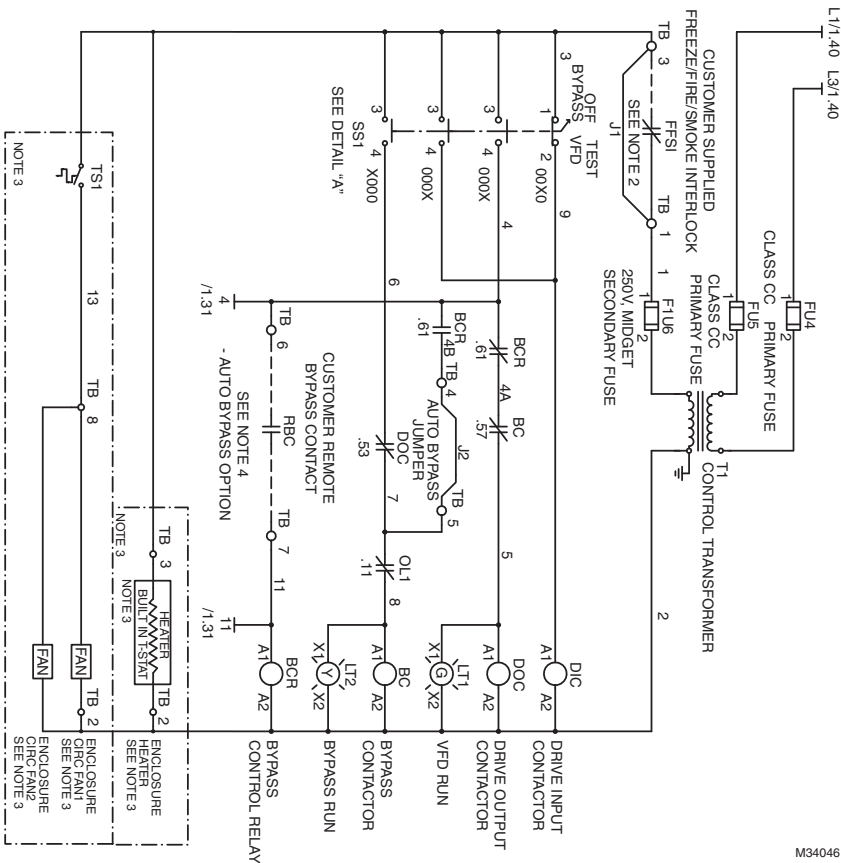
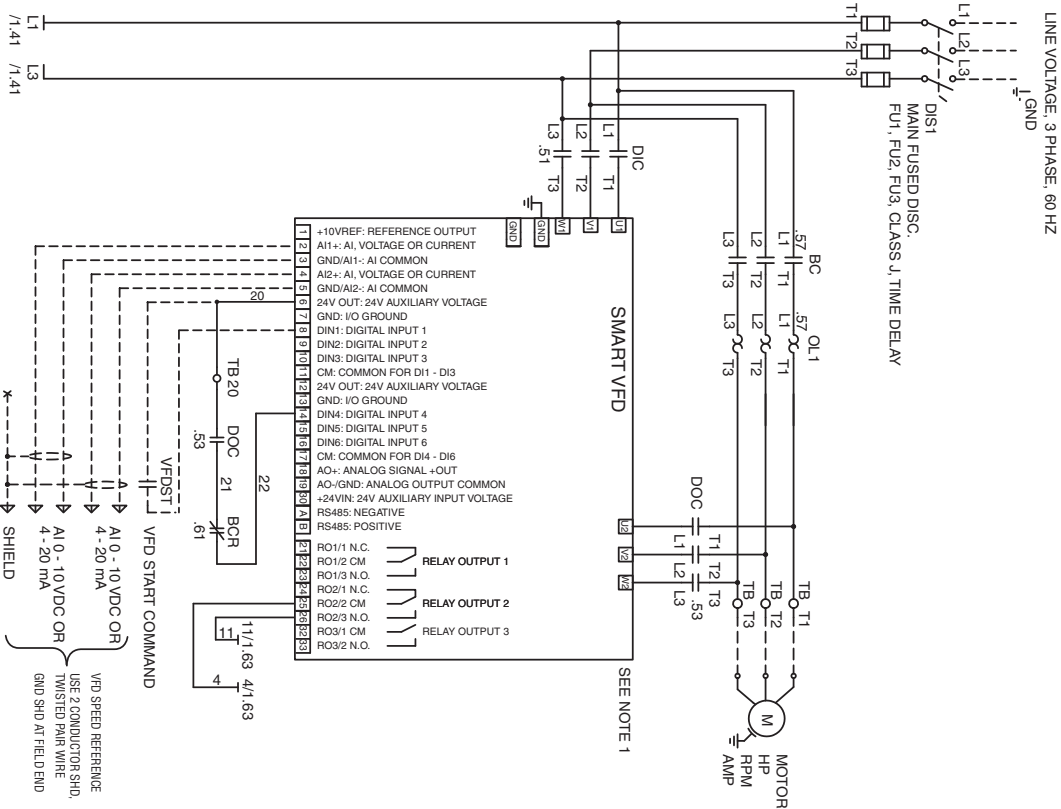
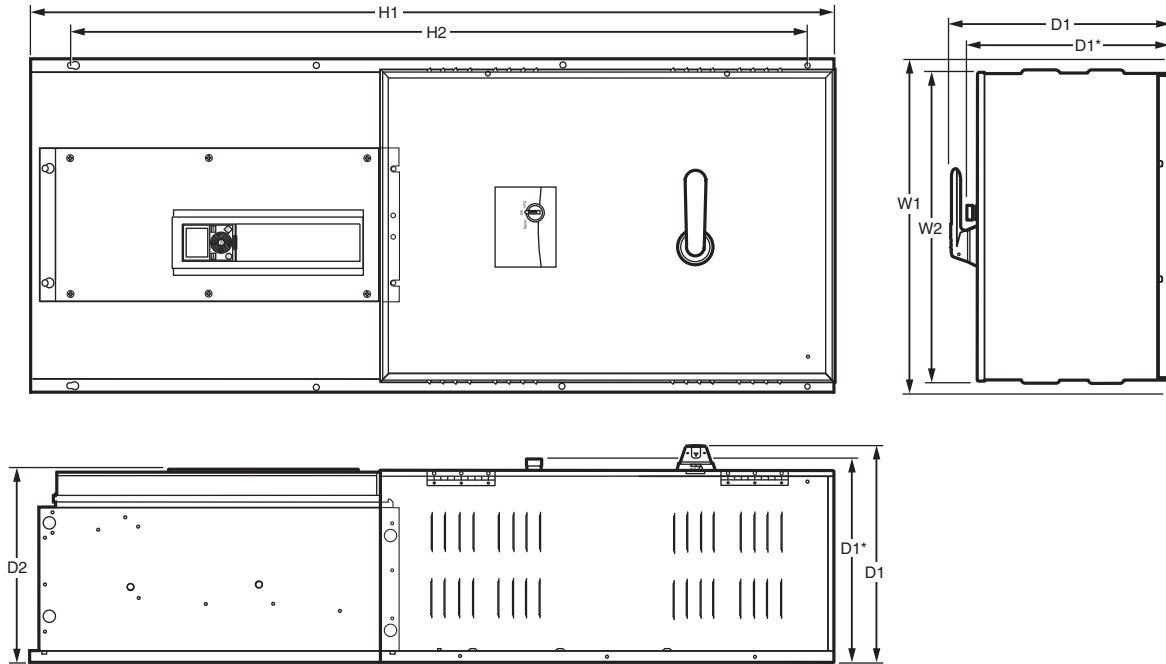

Fig. 4. Frame 8, 3 Contactor Auto-bypass Wiring Diagram.

SMARTVFD FRAME 8 WIRING DIAGRAMS AND DIMENSIONAL DRAWINGS



NOTE: TWO CONTACTOR DOES NOT COME WITH A DISCONNECT HANDLE.

M33827

Frame Size	HP and Voltage		Configuration	Dimensions						Weight (approx.)
	208/230	460Vac		W1	W2	H1	H2	D1	D2	Lb.
8	50HP	100HP	Disconnect	25	23.41	60	55	16.27	14.55	200
* depth of 2 CONT only			2-Contactor	25	23.41	60	55	*15.28	14.55	250
8	60HP	125HP	Disconnect	25	23.41	60	55	16.27	14.55	200
			2-Contactor	25	23.41	60	55	*15.28	14.55	265
8	75HP	150HP	Disconnect	25	23.41	60	55	16.27	14.55	200
			2-Contactor	25	23.41	60	55	*15.28	14.55	280

Fig. 5. Frame 8 NEMA 1: Disconnect only and 2 Contactor Dimensional Drawing.

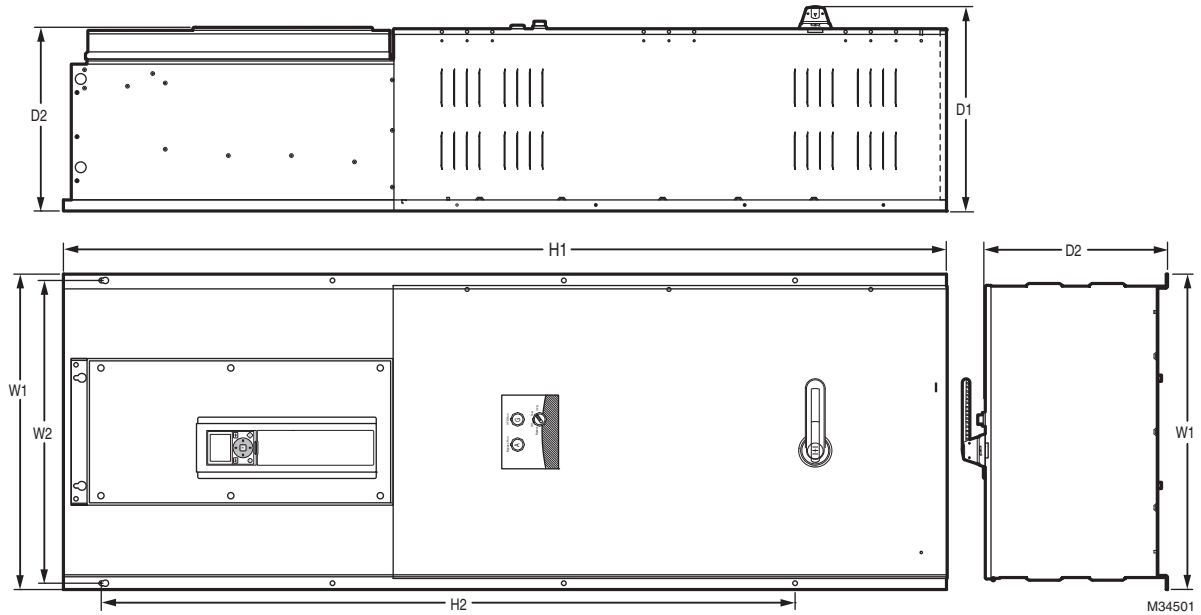

Frame Size	HP and Voltage		Configuration	Dimensions						Weight (approx.) Lb.
	208/230 Vac	460Vac		W1	W2	H1	H2	D1	D2	
8	50HP	100HP	3-Contactor	25	24	70.06	55	16.2	14.6	285.8
			3-Contactor with Auto-Bypass	25	24	70.06	55	16.2	14.6	287
8	60HP	125HP	3-Contactor	25	24	70.06	55	16.2	14.6	295.3
			3-Contactor with Auto-Bypass	25	24	70.06	55	16.2	14.6	297
8	75HP	150HP	3-Contactor	25	24	70.06	55	16.2	14.6	331.3
			3-Contactor with Auto-Bypass	25	24	70.06	55	16.2	14.6	333

Fig. 6. Frame 8 NEMA1: 3 Contactor and 3 Contactor with Auto-Bypass Dimensional Drawing.

SMARTVFD FRAME 8 WIRING DIAGRAMS AND DIMENSIONAL DRAWINGS

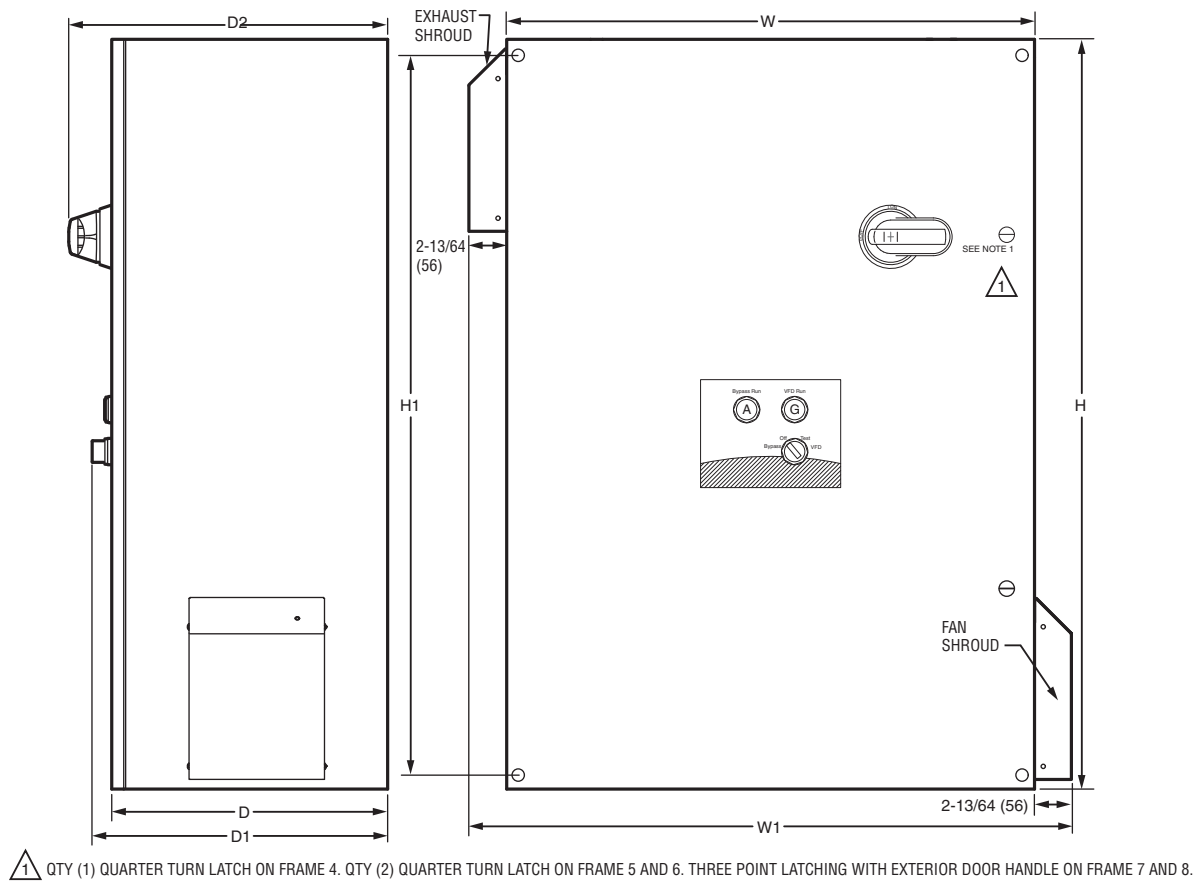

M34503

Frame Size	HP and Voltage		Configuration	Dimensions					Weight (approx.) Lb.	
	208/230 Vac	460Vac		H	H1	W	W1	D		D2
8	50HP, 60HP, 75HP	100HP, 125HP, 150HP	Disconnect Only	60	58.5	36	40.5	12	14	340
8	50HP, 60HP, 75HP	100HP, 125HP, 150HP	2-Contactor	60	58.5	36	40.5	12	12.5	430
8	50HP, 60HP, 75HP	100HP, 125HP, 150HP	3-Contactor	60	58.5	36	40.5	12	14	440
8	50HP, 60HP, 75HP	100HP, 125HP, 150HP	3-Contactor with Auto-bypass	60	58.5	36	40.5	12	14	440

Fig. 7. Frame 8 NEMA3R: Disconnect Only, 2 Contactor, 3 Contactor, and 3 Contactor with Auto- Bypass.

By using this Honeywell literature, you agree that Honeywell will have no liability for any damages arising out of your use or modification to, the literature. You will defend and indemnify Honeywell, its affiliates and subsidiaries, from and against any liability, cost, or damages, including attorneys' fees, arising out of, or resulting from, any modification to the literature by you.

Automation and Control Solutions

Honeywell International Inc.
1985 Douglas Drive North
Golden Valley, MN 55422
customer.honeywell.com



© U.S. Registered Trademark
© 2013 Honeywell International Inc.
63-1375—01 M.S. 01-13
Printed in United States